

# 8520A

## Digital Multimeter

Calibration Manual

P/N 541995  
December 1979

© 1981, John Fluke Mfg. Co., Inc., all rights reserved Litho in U.S.A



# WARRANTY

Notwithstanding any provision of any agreement the following warranty is exclusive:

The JOHN FLUKE MFG. CO., INC., warrants each instrument it manufactures to be free from defects in material and workmanship under normal use and service for the period of 1-year from date of purchase. This warranty extends only to the original purchaser. This warranty shall not apply to fuses, disposable batteries (rechargeable type batteries are warranted for 90-days), or any product or parts which have been subject to misuse, neglect, accident, or abnormal conditions of operations.

In the event of failure of a product covered by this warranty, John Fluke Mfg. Co., Inc., will repair and calibrate an instrument returned to an authorized Service Facility within 1 year of the original purchase; provided the warrantor's examination discloses to its satisfaction that the product was defective. The warrantor may, at its option, replace the product in lieu of repair. With regard to any instrument returned within 1 year of the original purchase, said repairs or replacement will be made without charge. If the failure has been caused by misuse, neglect, accident, or abnormal conditions of operations, repairs will be billed at a nominal cost. In such case, an estimate will be submitted before work is started, if requested.

THE FOREGOING WARRANTY IS IN LIEU OF ALL OTHER WARRANTIES, EXPRESS OR IMPLIED, INCLUDING BUT NOT LIMITED TO ANY IMPLIED WARRANTY OF MERCHANTABILITY, FITNESS, OR ADEQUACY FOR ANY PARTICULAR PURPOSE OR USE. JOHN FLUKE MFG. CO., INC., SHALL NOT BE LIABLE FOR ANY SPECIAL, INCIDENTAL, OR CONSEQUENTIAL DAMAGES, WHETHER IN CONTRACT, TORT, OR OTHERWISE.

**If any failure occurs, the following steps should be taken:**

1. Notify the JOHN FLUKE MFG. CO., INC., or nearest Service facility, giving full details of the difficulty, and include the model number, type number, and serial number. On receipt of this information, service data, or shipping instructions will be forwarded to you.
2. On receipt of the shipping instructions, forward the instrument, transportation prepaid. Repairs will be made at the Service Facility and the instrument returned, transportation prepaid.

## **SHIPPING TO MANUFACTURER FOR REPAIR OR ADJUSTMENT**

All shipments of JOHN FLUKE MFG. CO., INC., instruments should be made via United Parcel Service or "Best Way" prepaid. The instrument should be shipped in the original packing carton; or if it is not available, use any suitable container that is rigid and of adequate size. If a substitute container is used, the instrument should be wrapped in paper and surrounded with at least four inches of excelsior or similar shock-absorbing material.

## **CLAIM FOR DAMAGE IN SHIPMENT TO ORIGINAL PURCHASER**

The instrument should be thoroughly inspected immediately upon original delivery to purchaser. All material in the container should be checked against the enclosed packing list. The manufacturer will not be responsible for shortages against the packing sheet unless notified immediately. If the instrument is damaged in any way, a claim should be filed with the carrier immediately. (To obtain a quotation to repair shipment damage, contact the nearest Fluke Technical Center.) Final claim and negotiations with the carrier must be completed by the customer.

The JOHN FLUKE MFG. CO., INC., will be happy to answer all applications or use questions, which will enhance your use of this instrument. Please address your requests or correspondence to: JOHN FLUKE MFG. CO., INC., P.O. BOX C9090, EVERETT, WASHINGTON 98206, ATTN: Sales Dept. For European Customers: Fluke (Holland) B.V., P.O. Box 5053, 5004 EB, Tilburg, The Netherlands.

\*For European customers, Air Freight prepaid.

**John Fluke Mfg. Co., Inc., P.O. Box C9090, Everett, Washington 98206**

# Table of Contents

SECTION	TITLE	PAGE
<b>1</b>	<b>INTRODUCTION AND SPECIFICATIONS</b>	<b>1-1</b>
	1-1. THE 8520A INSTRUCTION MANUAL SET .....	1-1
	1-4. LIST OF RECOMMENDED TEST EQUIPMENT .....	1-3
	1-6. SPECIFICATIONS .....	1-3
<b>2</b>	<b>SHIPPING AND SERVICE INFORMATION</b>	<b>2-1</b>
	2-1. SHIPPING INFORMATION .....	2-1
	2-4. SERVICE INFORMATION .....	2-1
	2-7. QUESTIONS .....	2-1
<b>3</b>	<b>ACCESS PROCEDURES</b>	<b>3-1</b>
	3-1. INTRODUCTION .....	3-1
	3-3. MAINTENANCE AND ROUTINE CALIBRATION ACCESS ..	3-1
	3-5. NON-ROUTINE CALIBRATION ACCESS .....	3-1
<b>4</b>	<b>GENERAL MAINTENANCE</b>	<b>4-1</b>
	4-1. INTRODUCTION .....	4-1
	4-3. CLEANING INSTRUCTIONS .....	4-1
	4-5. LINE VOLTAGE SELECTION .....	4-1
	4-7. FUSE REPLACEMENT .....	4-1
<b>5</b>	<b>PERFORMANCE TEST</b>	<b>5-1</b>
	5-1. INTRODUCTION .....	5-1
	5-5. EQUIPMENT PREPARATION .....	5-1
	5-7. ZERO VERIFICATION .....	5-1
	5-9. DC VOLTS VERIFICATION .....	5-2
	5-11. RESISTANCE VERIFICATION .....	5-4
	5-13. AC VOLTAGE VERIFICATION .....	5-4

TABLE OF CONTENTS, *continued*

SECTION	TITLE	PAGE
<b>6</b>	<b>CALIBRATION ADJUSTMENTS</b>	<b>6-1</b>
6-1.	ROUTINE CALIBRATION ADJUSTMENTS .....	6-1
6-2.	Introduction .....	6-1
6-8.	Calibration (Cal) Digit .....	6-1
6-11.	Routine Calibration Preparation .....	6-2
6-13.	Reference Supply .....	6-2
6-15.	A/D Converter .....	6-2
6-17.	DC Buffer .....	6-4
6-19.	Ohms Converter .....	6-5
6-21.	AC Converter .....	6-5
6-23.	NON-ROUTINE CALIBRATION ADJUSTMENTS .....	6-7
6-24.	Introduction .....	6-7
6-26.	Preparing for Non-Routine Calibration .....	6-7
6-28.	Power Supply .....	6-7
6-30.	Auto Zero .....	6-8
6-32.	Reference Amplifier .....	6-8

## List of Tables

TABLE	TITLE	PAGE
1-1.	Test Equipment .....	1-3
1-2.	8520A Specifications .....	1-3
2-1.	Fluke Technical Service Centers - U.S. and Canada .....	2-2
2-2.	Fluke Technical Service Centers - International .....	2-2
2-3.	Sales Representatives - U.S. and Canada .....	2-4
2-4.	Sales Representatives - International .....	2-5
5-1.	Zero Verification .....	5-2
5-2.	Low DC Volts Verification .....	5-3
5-3.	High DC Volts Verification .....	5-3
5-4.	Resistance Verification .....	5-4
5-5.	AC Voltage Verification .....	5-5
6-1.	A/D Converter Calibration .....	6-3
6-2.	A/D Converter Tests .....	6-4
6-3.	Ohms Converter Calibration .....	6-6
6-4.	AC Converter AC+DC Calibration .....	6-7
6-5.	AC Converter AC Calibration .....	6-7



## List of Illustrations

FIGURE	TITLE	PAGE
	8520A Digital Multimeter .....	vi
1-1.	8520A Instruction Manual Set .....	1-2
1-2.	Outline Drawing .....	1-8
3-1.	Maintenance and Routine Calibration Access .....	3-2
3-2.	Non-Routine Calibration Access .....	3-3
4-1.	Line Voltage Selection Switches .....	4-2
5-1.	DC Voltage Verification .....	5-3
6-1.	A/D Converter Calibration .....	6-3
6-2.	Auto Zero Calibration Waveform .....	6-8

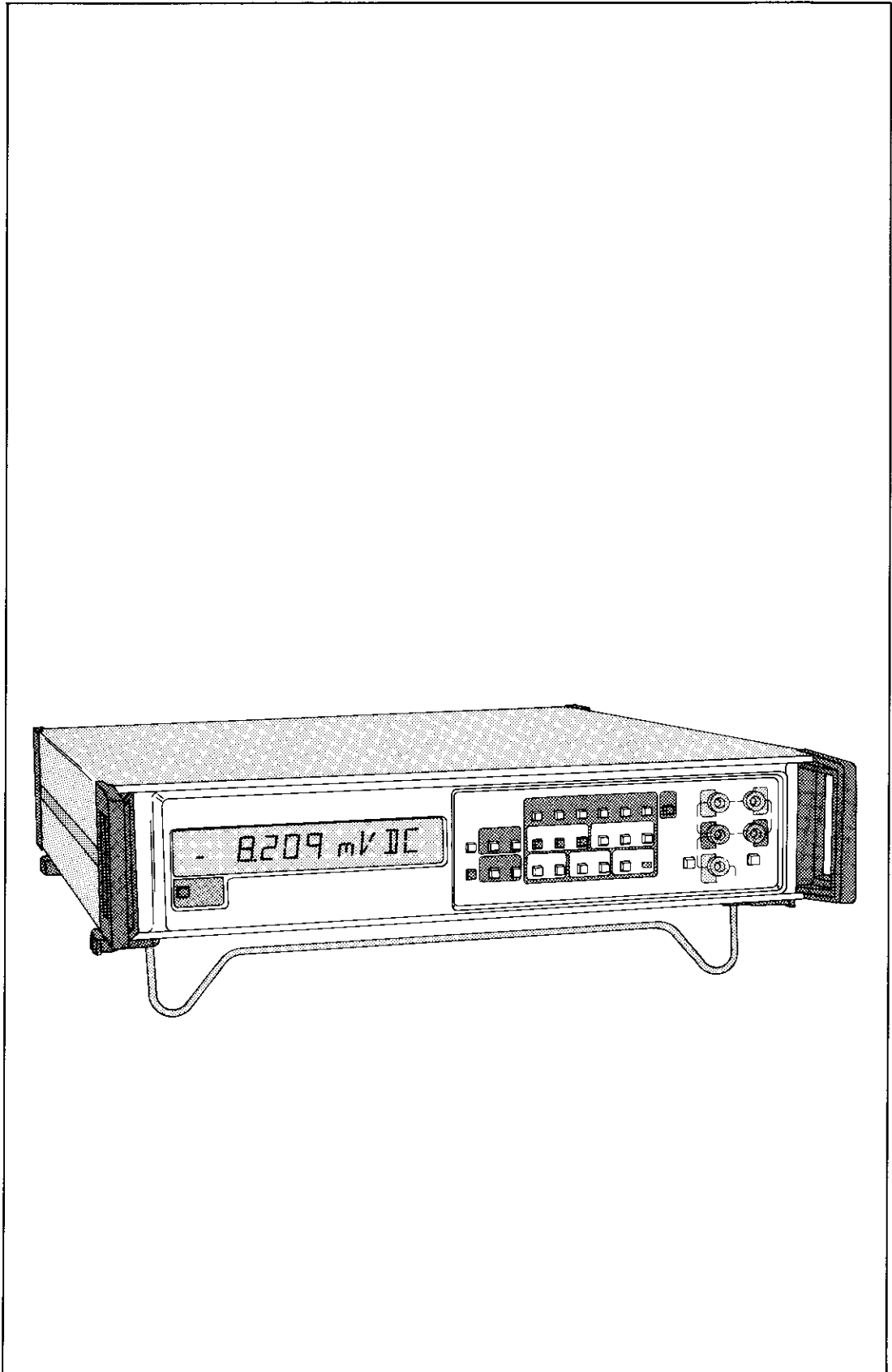

8520A Digital Multimeter



## Section 1

# Introduction and Specifications

### WARNING

**THESE SERVICING INSTRUCTIONS ARE FOR USE BY QUALIFIED PERSONNEL ONLY. TO AVOID ELECTRIC SHOCK, DO NOT PERFORM ANY SERVICING OTHER THAN THAT CONTAINED IN THE OPERATING INSTRUCTIONS UNLESS YOU ARE QUALIFIED TO DO SO.**

### 1-1. THE 8520A INSTRUCTION MANUAL SET

1-2. The John Fluke Model 8520A Digital Multimeter is documented by a set of three manuals: the 8520A Operator's Manual, the 8520A Calibration Manual, and the 8520A Service Manual. The 8520A Operator's Manual introduces the operator to the 8520A, familiarizes the operator with all instrument controls, connectors, and indicators, and presents detailed local and remote operating information and procedures. The 8520A Calibration Manual provides general maintenance procedures, Performance Tests, and Calibration Adjustment procedures. The 8520A Service Manual contains the theory of operation, troubleshooting information, a list of replaceable parts, and schematics. As Figure 1-1 shows, the three manuals can either be separated for use in different areas or joined together in a single binder.

1-3. The information in this, the 8520A Calibration Manual, is divided into six sections:

- |                                    |   |
|------------------------------------|---|
| 1 INTRODUCTION AND SPECIFICATIONS  | Introduces the 8520A Instruction Manual Set, lists the recommended test equipment necessary to complete the Performance Tests and Calibration Adjustments, and lists the instrument specifications. |
| 2 SHIPPING AND SERVICE INFORMATION | If there is a problem with your 8520A, how to get it corrected, and how to ship the instrument.   |
| 3 ACCESS PROCEDURES                | Describes how to gain access to the Calibration Adjustments and general maintenance circuit areas.  |

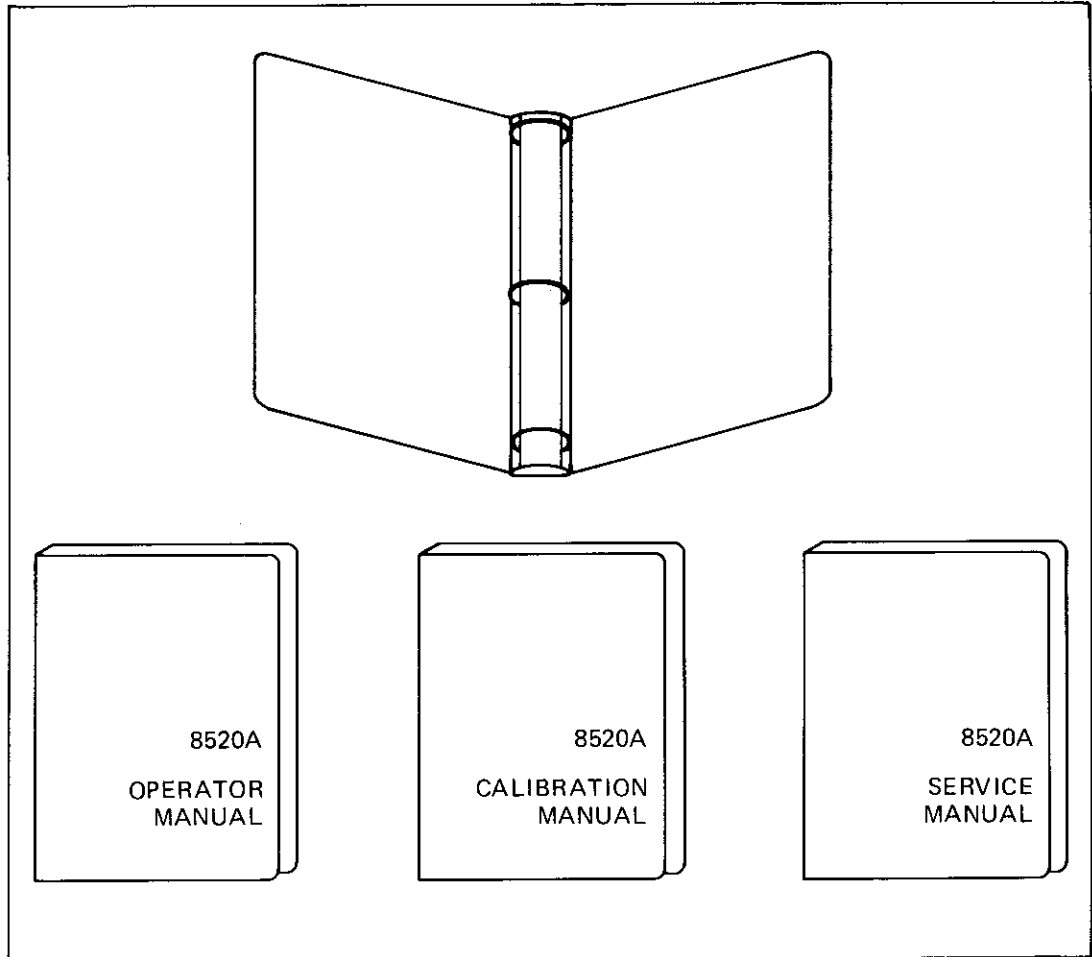

Figure 1-1. 8520A Instruction Manual Set

4 GENERAL MAINTENANCE

Describes how to replace fuses, select a different line voltage, clean the instrument, etc.

5 PERFORMANCE TESTS

A set of procedures that verify that the 8520A is performing within the specifications listed in Section I. All of these procedures are completed with the INSTRUMENT COVERS IN PLACE.

6 CALIBRATION ADJUSTMENTS

A set of procedures that tell how to perform the 8520A Calibration Adjustments so that the instrument operates within the specifications listed in Section I.

## 1-4. LIST OF RECOMMENDED TEST EQUIPMENT

1-5. Table 1-1, lists the test equipment required to complete the Performance Tests and Calibration Procedures described in this manual. Equivalent instruments can be substituted if the recommended models are not available.

## 1-6. SPECIFICATIONS

1-7. Table 1-2 lists the 8520A specifications.

Table 1-1. Test Equipment

ITEM	SPECIFICATIONS (MINIMUM)	NOMENCLATURE
DMM Oscilloscope DC Voltage Standard Ratio Standard  AC Calibrator Power Amplifier Standard Resistor w/Accessories	5½ digits 0.005% dc accuracy General Purpose 0.001% Accuracy 0.1 ppm Resolution, 1 ppm Terminal Linearity ≥0.03% Accuracy @ 20 kHz ≥0.044% Accuracy @ 20 kHz	FLUKE 8800A TEKTRONIX T900 Series FLUKE 332D or 335D FLUKE 720A  FLUKE 5200A FLUKE 5205A or 5215A ESI 1010 100Ω and 10 kΩ, ESI 1050 1MΩ. ESI SB103 shorting bars, ESI PC101 Parallel Compensation Network
Load	1 MΩ/1 μF	1 MΩ ±1% 1/8 W, mF resistor in parallel with a 1 μF ±20% 10V capacitor

Table 1-2. 8520A Specifications

DC VOLTS				
INPUT CHARACTERISTICS:				
RANGE	FULL-SCALE	RESOLUTION	INPUT RESISTANCE	
100 mV	199.999	1 μV	≥10,000 MΩ	
1V	1.99999	10 μV	≥10,000 MΩ	
10V	16.0100	100 μV	≥10,000 MΩ	
100V	130.100	1 mV	10 MΩ	
1000V	1024.00	10 mV	10 MΩ	
ACCURACY ±(% of input + number of digits)				
RANGE	24 HOURS 23°C ±1°C	90 DAYS 18°C to 28°C	1 YEAR 18°C to 28°C	PLUS TEMP. COEFFICIENT PER °C*
100 mV	0.003 + 5	0.0065 + 6	0.011 + 10	0.0005 + 0.5
1V	0.003 + 1	0.006 + 2	0.011 + 2	0.0005 + 0.15
10V	0.002 + 1	0.005 + 1	0.009 + 1	0.0004 + 0.10
100V	0.003 + 1	0.007 + 2	0.012 + 2	0.0005 + 0.15
1000V	0.0035 + 1	0.0065 + 1	0.011 + 1	0.0005 + 0.10

\*From 22°C to 0°C or 24°C to 50°C, 24 hours specification  
From 18°C to 0°C or 28°C to 50°C, 90 day or 1 year specification

Table 1-2. 8520A Specifications (cont)

**HIGH SPEED ACCURACY:  $\pm$ (% of input + least significant bit)\***

RANGE	90 DAYS 18°C to 28°C	1 YEAR 18°C to 28°C	PLUS TEMP. COEFFICIENT PER °C
100 mV	0.01 + 1	0.015 + 1	0.001 + .1
1V	0.01 + 1	0.015 + 1	0.001 + .05
10V	0.01 + 1	0.015 + 1	0.001 + .05
100V	0.01 + 1	0.015 + 1	0.001 + .05
1000V	0.01 + 1	0.015 + 1	0.001 + .05

\*Typical with 60 Hz line, remote operation, 500 readings per second, 2-byte binary output with 14 bits of data.

**TYPICAL NORMAL MODE REJECTION:**

LINE FREQ	FILTER SETTling TIME					
	25 ms	50 ms	100 ms	200 ms	500 ms	1s
50 Hz	65 dB	68 dB	71 dB	80 dB	*83 dB	86 dB
60 Hz	65 dB	68 dB	71 dB	85 dB	*88 dB	91 dB
400Hz	53 dB	56 dB	60 dB	120 dB	*123 dB	126 dB

\*Guaranteed minimum rejection

**COMMON MODE REJECTION:** True 100 dB at 50 Hz and 60 Hz with 1 k $\Omega$  unbalance in either lead. Effective CMR is equal to normal mode rejection plus true CMR.

**MAXIMUM INPUT:**  $\pm$ 1000V Peak, HI to LO or GUARD to chassis terminals, and  $\pm$  200V Peak, GUARD to LO terminals, for any range.

**MAXIMUM READING RATE:**

OPERATION	RESOLUTION	LINE	READING RATE
Local/Remote	5-1/2 digits	50 Hz	200 rdgs/sec
		60 Hz	240 rdgs/sec
Remote	4-1/2 digits	50 Hz	>500 rdgs/sec
		60 Hz	>500 rdgs/sec

Input Current  $\leq$ 50pA for 30 days @ 18° to 20°C

**AC VOLTS (TRUE RMS)****INPUT CHARACTERISTICS**

RANGE	FULL-SCALE	RESOLUTION	INPUT IMPEDANCE
1V	1.99999	10 $\mu$ V	1M $\Omega$ , $\leq$ 100pF at the V/ $\Omega$ INPUT terminal
10V	16.0100	100 $\mu$ V	
100V	130.100	1 mV	
650V	650.00	10 mV	

Table 1-2. 8520A Specifications (cont)

**ACCURACY:**  $\pm(\% \text{ of input} + \% \text{ of full-scale})$   
 For 650V range multiply % FS error shown by 1.6

FREQUENCY	24 HOURS 23°C±1°C			90 DAYS 23°C to 28°C			1 YEAR 18°C to 28°C		
	% of INPUT	+ % FS AC	+ % FS AC+DC	% of INPUT	+ % FS AC	+ % FS AC+DC	% of INPUT	+ % FS AC	+ % FS AC+DC
10 Hz to 20 Hz*	3.0	0.5	0.6	3.0	0.6	0.7	3.5	0.6	0.7
20 Hz to 40 Hz*	0.4	0.3	0.4	0.5	0.5	0.6	0.6	0.6	0.7
40 Hz to 20 kHz	0.08	0.02	0.06	0.1	0.03	0.08	0.15	0.05	0.16
20 kHz to 100 kHz	1.0	0.3	0.4	1.0	0.3	0.4	2.0	0.6	0.8
100 kHz to 300 kHz	2.4	0.6	0.6	2.4	0.6	0.6	4.0	1.0	1.0
300 kHz to 1 MHz	8.0	2.5	2.5	8.0	2.5	2.5	15.0	5.0	5.0

\*Assumes smoothing using the Statistics Math Program (#8).

**TEMPERATURE COEFFICIENT:** 18°C to 0°C or 28°C to 50°C, to 20 kHz.

AC MODE:  $\pm(.007\% \text{ of input} + .007\% \text{ FS})/^{\circ}\text{C}$

AC + DC MODE:  $\pm(.007\% \text{ of input} + .014\% \text{ FS})/^{\circ}\text{C}$

**MAXIMUM INPUT:**  $\pm 1000\text{V}$ , Peak HI to LO or GUARD to chassis terminals, and  $\pm 200\text{V}$  Peak GUARD to LO terminals for any range.

**CREST FACTOR:** Exceeds 4:1 @ full scale, increasing downscale.

**MAXIMUM READING RATE:** 10 rdgs/sec.

**OHMS**

**INPUT CHARACTERISTICS:**

RANGE	FULL-SCALE	RESOLUTION	CURRENT THRU UNKNOWN	OPEN CIRCUIT VOLTAGE
10Ω	19.9999	100 μΩ	10 mA	< 8V
100Ω	199.999	1 mΩ	10 mA	
1000Ω	1999.99	10 mΩ	1.0 mA	
10 kΩ	19.9999	100 mΩ	0.1 mA	
100 kΩ	199.999	1Ω	14.5 μA (max)	
1 MΩ	1.99999	10Ω	1.5 μA (max)	
10 MΩ	19.999	1 kΩ	1.5 μA (max)	

**ACCURACY:**  $\pm(\% \text{ of input} + \text{number of digits})$

RANGE	24 HOURS 23°C ± 1°C	90 DAYS 18°C to 28°C	1 YEAR 18°C to 28°C	PLUS TEMP. COEFFICIENT PER °C*
10Ω	0.0045 + 6	0.0080 + 7	0.0140 + 12	0.0007 + 0.2
100Ω	0.0035 + 2	0.0070 + 2	0.0125 + 3	0.0007 + 0.2
1000Ω	0.0035 + 2	0.0070 + 2	0.0125 + 3	0.0007 + 0.2
10kΩ	0.0035 + 2	0.0070 + 2	0.0125 + 3	0.0007 + 0.2
100kΩ	0.0040 + 2	0.0090 + 2	0.0140 + 3	0.0012 + 0.2
1MΩ	0.0090 + 2	0.0160 + 2	0.0200 + 3	0.0020 + 0.2
10MΩ	0.0300 + 1	0.0440 + 1	0.0450 + 3	0.0030 + 0.2

\*From 18°C to 0°C or 28°C to 50°C

Table 1-2. 8520A Specifications (cont)

**MAXIMUM INPUT:**  $\pm 400\text{V}$  peak for any range.

**MAXIMUM READING RATE:** 10/SEC at  $100\text{K}\Omega$  and above.

OPERATION	RESOLUTION	LINE	READING RATE
Local/Remote	5-1/2 digits	50 Hz	200 rdgs/sec
		60 Hz	240 rdgs/sec
Remote	4-1/2 digits	50 Hz	>500 rdgs/sec
		60 Hz	>500 rdgs/sec

### CONDUCTANCE

**RANGE:** 100 nS

**FULL-SCALE:** 202.00 nS

**RESOLUTION:** 0.01 nS

**ACCURACY:**  $\pm$ (% of input + number of digits)

24 HOURS $23^{\circ}\text{C} \pm 1^{\circ}\text{C}$	90 DAYS $18^{\circ}\text{C}$ to $28^{\circ}\text{C}$	1 YEAR $18^{\circ}\text{C}$ to $28^{\circ}\text{C}$	*PLUS TEMP. COEFFICIENT PER $^{\circ}\text{C}$
0.04 + 5	0.05 + 5	0.06 + 5	0.004 + 1

\*From  $18^{\circ}\text{C}$  to  $0^{\circ}\text{C}$  or  $28^{\circ}\text{C}$  to  $50^{\circ}\text{C}$

**MAXIMUM INPUT:**  $\pm 400\text{V}$  peak

**MAXIMUM READING RATE:** 10 rdgs/sec

### EXTERNAL REFERENCE

**OPERATING RANGE:**  $\pm 0.5\text{V}$  dc to  $\pm 33\text{V}$  dc as long as external reference is within  $\pm 16.5\text{V}$  of input LO terminal.

**INPUT IMPEDANCE:** 10,000  $\text{M}\Omega$  between external reference HI or LO terminals and input LO terminals.

**ACCURACY:**

X-REF VOLTAGE	ACCURACY
16.5V to 33V	$\pm(A + B + 20 \text{ ppm})$
0.5V to 16.5V	$\pm[A + B + (400 \text{ ppm} \div  V_{\text{ref}}  )]$

NOTE: A = DC 10 volt range accuracy

B = Input voltage or resistance range accuracy

**MAXIMUM INPUT:**  $\pm 180\text{V}$  peak between external reference HI or LO and input LO;  
 $\pm 360\text{V}$  peak between external reference HI and LO.

Table 1-2. 8520A Specifications (cont)

**TRANSFER ACCURACY:**

The following accuracy specifications apply when:

- Filter settling time is 500 or 1000 ms.
- Measurements are made more than 2 hours after warm-up.
- Measurements are made within one range.
- Standard is checked at least every hour.
- Ambient temperature stability within  $\pm 1^\circ\text{C}$ .

**DC VOLTAGE:**

RANGE	$\pm$ (% of input + number of digits)
100 mV	0.0020 + 4
1V	0.0020 + 1
10V	0.0010 + 1
100V	0.0020 + 1
1000V	0.0020 + 1

**AC VOLTAGE (all ranges):**

FREQUENCY	$\pm$ (% of input + % of full-scale)
10 Hz to 20 Hz	1.0 + 0.2
20 Hz to 40 Hz	0.1 + 0.1
40 Hz to 20 kHz	0.005 + 0.007
20 kHz to 100 kHz	0.100 + 0.030
100 kHz to 1 MHz	0.500 + 0.060

**AC VOLTAGE, DC COUPLED:** Same as AC Voltage except 40Hz - 20KHz, 0.005+0.010

**RESISTANCE:**

RANGE	$\pm$ (% of input + number of digits)
10 $\Omega$	0.0030 + 5
100 $\Omega$	0.0020 + 2
1000 $\Omega$	0.0020 + 2
10 k $\Omega$	0.0020 + 2
100 k $\Omega$	0.0020 + 2
1 M $\Omega$	0.0050 + 2
10 M $\Omega$	0.0100 + 1

**CONDUCTANCE:**  $\pm$ (0.02% of input + 0.02 nS)

**GENERAL:**

**INTERFACE:** IEEE-488-1978 is standard.

**TEMPERATURE:** 0°C to 50°C operating; -25°C to +75°C non-operating.

**RELATIVE HUMIDITY:**  $\leq$ 95% at 25°C,  $\leq$ 75% at 40°C,  $\leq$ 45% at 50°C.

**SHOCK AND VIBRATION:** Meets MIL-T-28800B for type III, Class 5, Style E.

Table 1-2. 8520A Specifications (cont)

**POWER:** 100, 120, 220, or 240V ac,  $\pm 10\%$ ; 50, 60, or 400 Hz  $\pm 5\%$ ,  $\leq 50W$ .

**SIZE:** 8.89 cm H/47.00 cm L/43.18 cm W—(3 1/2 in H/18 1/2 in L/17 in W)  
See Figure 1-2.

**WEIGHT:** 9.56 kg (21 lbs)

**PROTECTION CLASS CODE 1:** (Relates solely to insulation or grounding properties in IEC 348).

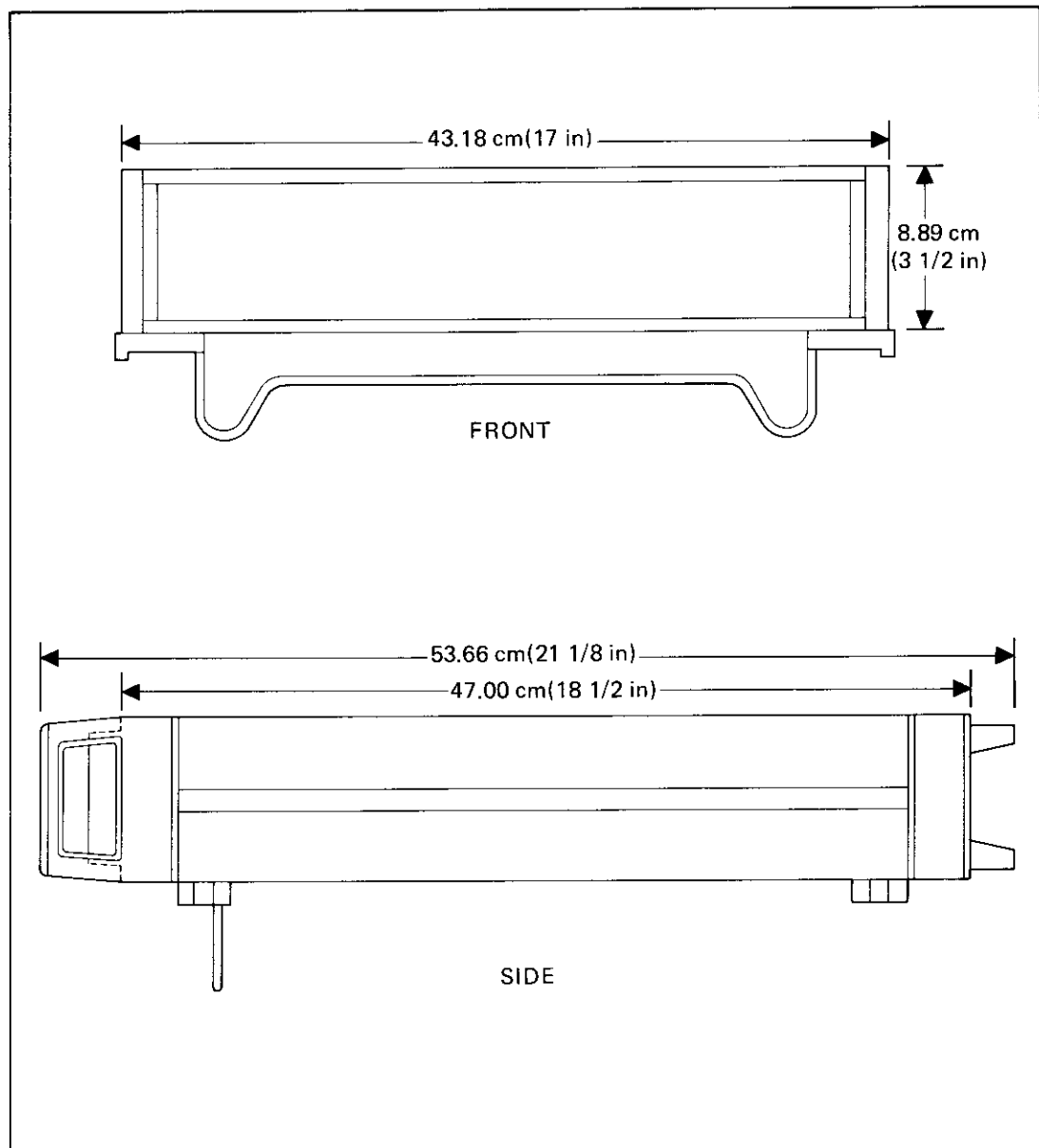

Figure 1-2. Outline Drawing



## Section 2

# Shipping and Service Information

### 2-1. SHIPPING INFORMATION

2-2. The 8520A is packaged and shipped in a foam-packed container. When you receive the 8520A, inspect the instrument thoroughly for possible shipping damage. Special instructions for inspection and claims are included on the shipping container.

2-3. If reshipment is necessary, use the original container. If the original container is not available, order a new container from John Fluke Mfg. Co., Inc./P.O. Box C9090/Everett, Washington 98206, telephone (206) 342-6300.

### 2-4. SERVICE INFORMATION

2-5. Each John Fluke Model 8520A Digital Multimeter is warranted for a period of one year upon delivery to the original purchaser. The WARRANTY is located at the front of this manual.

2-6. Factory authorized calibration and service for each Fluke product is available at various worldwide locations. The following pages provide a complete list of these service centers. If requested, the customer will be provided with an estimate before any work begins on instruments that are beyond the Warranty period.

### 2-7. QUESTIONS

2-8. For additional information, contact your nearest John Fluke Sales Representative (see following pages), or the John Fluke Mfg. Co., Inc. at the address or telephone number given above.



# TECHNICAL SERVICE CENTERS

## U.S.A.

### CA, Burbank

John Fluke Mfg. Co., Inc.  
(213) 849-4641

### CA, Santa Clara

John Fluke Mfg. Co., Inc.  
(408) 727-8121

### CO, Denver

John Fluke Mfg. Co., Inc.  
(303) 750-1228

### FL, Orlando

John Fluke Mfg. Co., Inc.  
(305) 896-2296

### IL, Rolling Meadows

John Fluke Mfg. Co., Inc.  
(312) 398-5800

### MA, Burlington

John Fluke Mfg. Co., Inc.  
(617) 273-4678

### MD, Rockville

John Fluke Mfg. Co., Inc.  
(301) 770-1576

### NJ, Paramus

John Fluke Mfg. Co., Inc.  
(201) 262-9550

### TX, Dallas

John Fluke Mfg. Co., Inc.  
(214) 233-9945

### WA, Everett

John Fluke Mfg. Co., Inc.  
(206) 356-5560

## Other Countries

### Argentina, Buenos Aires

Coasin S.A.  
Tel: 552-5248/3485  
TLX: 122284 COASN AR

### Australia, Concord

Elmeasco Instruments Pty Ltd.  
Tel: (02) 736-2888  
TLX: (790) 25887

### Australia, Mount Waverley

Elmeasco Instruments Pty Ltd.  
Tel: 03-233-4044  
TLX: 36206

### Australia, Brisbane

Elmeasco Instruments Pty Ltd.  
Tel: (07) 229-3161

### Austria, Vienna

Walter Rekirisch Elektronische Gerate  
GmbH & Co.  
Tel: (0222) 235555  
TLX: 134759

### Belgium, Brussels

Fluke (Belgium) SA/NA  
Tel: (02) 2164090  
TLX: 26312

### Brazil, Sao Paulo

Fluke Brasil-Industria E Comercio Ltda.  
Tel: (011) 421-3603  
TLX: 01135589 FLKE BR

### Canada, Calgary, AB

Allan Crawford Associates Ltd.  
Tel: (403) 230-1341

### Canada, Burnaby, BC

Allan Crawford Associates Ltd.  
Tel: (604) 294-1326

### Canada, Mississauga, ON

Allan Crawford Associates Ltd.  
Tel: (416) 678-1500

### Canada, St. Laurent, PQ

Allan Crawford Associates Ltd.  
Tel: (514) 731-8564

### Chile, Santiago

Intronica Chile Ltda.  
Tel: 44940  
TLX: 240301

### China, Beijing

Beijing Radio Research Institute  
Tel: 445612

### Colombia, Bogota

Sistemas E Instrumentacion, Ltda.  
Tel: 232-45-32  
TLX: 45787 COASN CO

### Denmark, Ballerup

Tage Olsen A/S  
Tel: (02) 658111  
TLX: 35293 TOAS SK

### Ecuador, Quito

Edificio "Jerico"  
Tel: 529684, 526759  
TLX: 2865 Protec Ed

### Egypt, Cairo

Electronic Engineering Liaison Office  
Tel: 691588  
TLX: (927) 92502

### England, Watford, Herts

Fluke (Great Britain) LTD  
Tel: 44-923-40511  
TLX: 934583

### Finland, Kaunialainen

Oy Findip AB  
Tel: (0) 5052255  
TLX: 123129

### France, BUC

M.B. Electronique S.A.  
Tel: (01) 9568131  
TLX: 695414

### Greece, Athens

Hellenic Scientific Representations  
Tel: (01) 711140  
TLX: 219330

### Hong Kong, Hong Kong

Schmidt & Co. (H.K.) Ltd.  
Tel: 5-455644  
TLX: 74766 SCHMC HX

### India, Bombay

Hinditron Services Pvt. Ltd.  
Tel: 811316, 815344  
TLX: 953-112326 HSPL IN

### India, Bangalore

Hinditron Services Pvt. Ltd.  
Tel: 33139  
TLX: 0845741

### India, New Delhi

Hinditron Services Pvt. Ltd.  
Tel: 619118  
TLX: 031 4890 SRMP IN

### Indonesia, Jakarta Selatan

P.T. Dwi Tunggal Jaya Sakti  
Tel: 716374  
TLX: 47308 DIJS IA

### Israel, Ramat Hasharon

R.D.T. Electronics Engineering Ltd.  
Tel: (03) 483216  
TLX: 32143

### Italy, Milan

Sistrel S.p.A.  
Tel: (02) 6181893  
TLX: 334643

### Italy, Rome

Sistrel S.p.A.  
Tel: (06) 5915551  
TLX: 68356

### Japan, Tokyo

John Fluke Mfg. Co., Inc.  
Japan Branch  
Tel: (03) 434-0181  
TLX: (781) 2424331 (FLUKJPJ)

### Korea, Seoul

Electro-Science Korea Co.  
Tel: 261-7702, 260-1908  
TLX: K25381

### Malaysia, Petaling Jaya

Mecomb Malaysia SDN BHD  
Tel: 573455  
TLX: MA37605

### Mexico, Mexico D.F.

Electronica y Tecnologia  
Avanzada S.A. de C.V. (ETA)  
Tel: 393 09 02 or 393 57 62  
TLX: 0172697 BLOSME

### Netherlands, Maarssen

Fluke (Nederland) B.V.  
Tel: (030) 436514  
TLX: 47128

### Netherlands, Tilburg

Fluke (Holland) B.V.  
Tel: (013) 673973  
TLX: 52237

### New Zealand, Auckland

McLean Information Technology, Ltd.  
Tel: 501-801, 501-219, 587-037  
TLX: NZ21570 THERMAL

### Norway, Oslo

Morgenstjerne & Co A/S  
Tel: (02) 356110  
TLX: 71719

### Pakistan, Karachi

Pak International Operations  
Tel: 221127, 239052  
TLX: 24494 PIO PK

### Peru, Lima

Importaciones Y Representaciones  
Electronicas S.A.  
Tel: 288650  
TLX: 37425663

### Philippines, Metro Manila

Spark Radio & Electronics Corp.  
Tel: 78-78-16  
TLX: 27901 RLA PH

### Portugal, Lisboa

Decada-Equipamentos de  
Electronica, Lda.  
Tel: (19) 574984  
TLX: 18469

### Republic of Singapore, Singapore

Rank O'Connor's (PTE) Limited  
Tel: 637944, 239052  
TLX: OCONSIN RS21023

### Republic of South Africa, Bramley

Fluke S.A. (Pty) Ltd  
Tel: (011) 786-3170  
TLX: 424328

### Spain, Alcorcon (Madrid)

Hispano Electronics S.A.  
Tel: (01) 6194108  
TLX: 22404/42634

### Sweden, Vallingby

Teleinstrument AB  
Tel: (08) 380370  
TLX: 15770

### Switzerland, Zurich

Traco Electronic AG  
Tel: (01) 2010711  
TLX: 54318

### Taiwan, Taipei

Schmidt Scientific Far East Ltd.  
Tel: 5414600  
TLX: 11111 Schmidt

### Thailand, Bangkok

Measuretronix Ltd.  
Tel: 3143369, 3143430  
TLX: 81143 DEJOBKK TH

### Turkey, Istanbul

Erkman Elektronik Aletler  
Tel: (01) 5461  
TLX: 23353

### Uruguay, Montevideo

Coasin Uruguay S.R.L.  
Tel: 29-31-952  
TLX: UY 6571 OROCUER

### Venezuela, Caracas

Coasin, C.A.  
Tel: 38-78-42, 38-78-86  
TLX: 21027 EMVEN VE

### West Germany, Ismaning

Fluke (Deutschland) GmbH  
Tel: (089) 96050  
TLX: 0522472



# INTERNATIONAL SALES OFFICES

## Argentina •

Coasin, S.A.  
Virrey del Pino 4071  
Buenos Aires, Argentina  
Tel: 552-5248, TLX: 22284

## Australia •

Elmeasco Instruments Pty Ltd.  
P.O. Box 30, Concord, N.S.W.  
Australia 2137  
Tel: (2) 736-2888, TLX: (790) 25887

Elmeasco Instruments Pty Ltd.  
21-23 Anthony Drive  
Mt. Waverley, VIC 3149  
Australia  
Tel: 233-4044, TLX: (790) 36206

Elmeasco Instruments Pty Ltd  
Professional Suites Bldg.  
G.P.O. Box 2360  
Brisbane, 4001, Australia  
Tel: (07) 229-3161

Elmeasco Instruments Pty Ltd.  
G.P.O. Box 1240, Adelaide  
South Australia 5001  
Tel: (08) 271-1839

Elmeasco Instruments Pty. Ltd.  
P.O. Box 95, Gosnells  
West Australia 6110  
Tel: (09) 398-3362

## Austria •

Walter Rekersch  
Elektronische Geräte GmbH & Co.  
Vertrieb KG  
Obachgasse 28  
Vienna, Austria  
Tel: (0222) 235555, TLX: 134759

## Bangladesh •

Motherland Corporation  
24 Hatkhola Rd., Tikatuli  
Dacca 3, Bangladesh  
Tel: 257249 or 255776

## Belgium •

Fluke (Belgium) S.A./N.V.  
6, Rue de Geneve  
1140 Brussels, Belgium  
Tel: (2) 2164090, TLX: 26312

## Bolivia •

Coasin Bolivia S.R.L.  
Casilla 7295, La Paz, Bolivia  
Tel: 40962, TLX: 3233

## Brazil •

Fluke Brasil-Industria E  
Comercio LTDA  
Al. Amazonas 422,  
Alphaville, Barueri,  
CEP 06400 Sao Paulo, Brazil  
Tel: (011) 421-5477, TLX: 01135589

Fluke Brasil-Industria E  
Comercio LTDA  
Av. Henrique Valadares, 23/401  
Rio de Janeiro, Brazil  
Tel: 252-1297

## Brunel •

Rank O'Connor's (PTE) Limited  
No. 8, BK D  
Surfri Shop House Complex  
Mile 1, Jalong Tutong  
Bandar Seri Begawan, Brunel  
Tel: 26680

## Bulgaria •

Amtest Associates Ltd.  
Clarence House, 31, Clarence St.  
Staines, Middlesex TW18 4SY  
United Kingdom  
Tel: (784) 63555, TLX: 928855

## Canada •

Allan Crawford Assoc., Ltd.  
#14 1935 30th Ave. N.E.  
Calgary, Alberta T2E 6Z5  
Tel: (403) 230-1341, TLX: 83-021186

Allan Crawford Assoc., Ltd.  
P.O. Bag 3967  
Postal Station "D"  
Edmonton, Alberta T5L 4K1  
Tel: (403) 451-4893

Allan Crawford Assoc., Ltd.  
3795 William Street  
Burnaby, British Columbia V5C 3H3  
Tel: (604) 294-1326, TLX: 04-54247

Allan Crawford Assoc., Ltd.  
881 Lady Ellen Place  
Ottawa, Ontario K1Z 5L3  
Tel: (613) 722-7682, TLX: 0533600

Allan Crawford Assoc., Ltd.  
6503 Northam Drive  
Mississauga, Ontario L4V 1J2  
Tel: (416) 678-1500, TLX: 06968769

Allan Crawford Assoc., Ltd.  
7918 cote de Liesse  
St. Laurent, Quebec H4T 1E7  
Tel: (514) 731-8564, TLX: 05824944

## Chad •

Fluke (Holland) B.V.  
P.O. Box 5053, 5004 EB Tilburg  
Zevenheuvelenweg 53, 5048 AN Tilburg  
The Netherlands  
Tel: (013) 673973, TLX: 52237

## Chile •

Intronica Chile Ltda  
Manuel Montt 024 - Of. D  
Casilla 16228, Santiago 9, Chile  
Tel: 44940, TLX: 240301  
Attn: Intronica Chile

## China, People's Republic of •

Fluke International Corporation  
P.O. Box C9090  
Everett, WA 98206, U.S.A.  
Tel: (206) 356-5511  
TLX: 152662 JOHN FLUKE EVT

## Colombia •

Sistemas E Instrumentacion, Ltda.  
Carrera 13, No. 37-43, Of. 401  
Ap. Aereo 29583  
Bogota DE, Colombia SA  
Tel: 232-45-32, TLX: 45787

## Cyprus •

Chris Radiovision Ltd.  
P.O. Box 1989, Nicosia, Cyprus  
Tel: 66121, TLX: 8262395

## Czechoslovakia •

Amtest Associates Ltd.  
Clarence House, 31, Clarence St.  
Staines, Middlesex TW18 4SY  
United Kingdom  
Tel: (784) 63555, TLX: 928855

## Denmark •

Tage Olsen A/S  
Ballerup Byvej 222  
DK - 2750 Ballerup, Denmark  
Tel: (2) 658111, TLX: (855) 35293

## Ecuador •

Proteco Coasin Cia., Ltda.  
Edificio "Jerico"  
Ave. 12 de Octubre #2285 y  
Ave. Orellana (Planta Baja)  
Quito, Ecuador  
Tel: 529684, TLX (393) 2865  
Proteco Coasin Cia., Ltda  
Calderon 103 y Malecon  
Casilla #9733  
Guayaquil, Ecuador  
Tel: 526093

## Egypt and Sudan •

Electronic Engineering Liaison Office  
P.O. Box 2891 Horreya  
Heliopolis, Cairo, Egypt  
Tel: 691588, TLX: (927) 92502

## England •

Fluke (Great Britain) LTD.  
Colonial Way  
Watford, Herts. WD2 4TT  
United Kingdom  
Tel: (0923) 40511, TLX: (851) 934583  
Rapifax: (0923) 25067

## Ethiopia •

Fluke (Holland) B.V.  
P.O. Box 5053, 5004 EB Tilburg  
Zevenheuvelenweg 53, 5048 AN Tilburg  
The Netherlands  
Tel: (013) 673973, TLX: 52237

## Fiji •

AWA Fiji  
47 Forster Road, Walu Bay  
Suva, Fiji  
Tel: 312079, TLX: FJ2347

## Finland •

Oy Findip AB, Teollisuustie 7  
02700 Kaunainen, Finland  
Puh: (0) 5052255, TLX: (857) 123129

## France •

M.B. Electronique S.A.  
Rue Fourny 606, Z1 Centre  
78530 BUC  
B.P. No 31  
78530 BUC, France  
Tel: (3) 9568131, TLX: (842) 695414

## German Democratic Republic •

Amtest Associates Ltd  
Clarence House, 31, Clarence St.  
Staines, Middlesex TW18 4SY  
United Kingdom  
Tel: (784) 63555, TLX: 928855

## German Federal Republic •

Fluke (Deutschland) GmbH  
Max-Hueber StraBe 8  
8045 Ismaning, West Germany  
Tel: (089) 96050, TLX: 522472  
Rapifax: (089) 9605166  
Fluke (Deutschland) GmbH  
Meineckestrasse 53  
4000 Dusseldorf 30, West Germany  
Tel: (0211) 450831, TLX: (841) 858576

## Greece •

Hellenic Scientific Representations Ltd.  
11, Vrasside Street  
Athens 612, Greece  
Tel: (1) 711140, TLX: (863) 219330

## Hong Kong •

Schmidt & Co. (H.K.) Ltd.  
28th Fl. Wing on Centre  
111 Connaught Road  
Central Hong Kong  
Tel: 5-455644  
TLX: 74766

## Hungary •

Amtest Associates Ltd.  
Clarence House, 31, Clarence St.  
Staines, Middlesex TW18 4SY  
United Kingdom  
Tel: (784) 63555, TLX: 928855

## Iceland •

Kristjan O. Skagfjord Ltd  
P.O. Box 906  
Reykjavik, Iceland  
Tel: 24120, TLX: 2133

## India •

Hinditron Services Pvt. Ltd.  
69/A.L. Jagmohandas Marg  
Bombay 400 006, India  
Tel: 811316, TLX: 112326

Hinditron Services Pvt. Ltd.  
8th Main Road  
33/44-A Raj Mahl Vilas Extension  
Bangalore 560 080, India  
Tel: 33139, TLX: (953) 0845741

Hinditron Services Pvt. Ltd.  
Shantiniketan, Office No 6  
6th Floor, 8 Camac Street  
Calcutta 700 017, India  
Tel: 434032, 447541

Hinditron Services Pvt. Ltd.  
204-206 Henkunt Tower  
98 Nehri Place  
New Delhi, 110019, India  
Tel: 640380, TLX: (95) 314890

Hinditron Services Pvt. Ltd.  
Srnath Complex, 5th Floor  
1-1-58/1 to 1-1-58/11  
Sarajini Devi Road  
Secunderabad 500 003, India  
Tel: 821117, TLX: (953) 0155 575

## Indonesia •

P.T. Dwi Tunggal Jaya Sakti  
Kebayoran Baru  
Jakarta Selatan, Indonesia  
Tel: 716374, TLX: 45305

## Iraq •

Fluke (Holland) B.V.  
P.O. Box 5053, 5004 EB Tilburg  
Zevenheuvelenweg 53, 5048 AN Tilburg  
The Netherlands  
Tel: (013) 673973, TLX: 52237

## Ireland •

Euro Electronics  
32 Brews Hill  
Naven County Meath, Ireland  
Tel: (46) 23577, TLX: (851) 3182

## Israel •

R.D.T. Electronics Engineering Ltd.  
P.O. Box 75  
46, Sokolov Street  
Ramat Hasharon 47235, Israel  
Tel: (3) 483216, TLX: (922) 32143

## Italy •

Sistrel S.p.A.  
Via Pelizza da Volpedo 59  
20092 Cinisello Balsamo  
Milan, Italy  
Tel: (2) 6181893, TLX: (843) 334643

Sistrel S.p.A.  
Via Giuseppe Armellini No. 39  
00143 Rome, Italy  
Tel: (6) 5915551, TLX: (843) 68356

Sistrel S.p.A.  
Via Cinto  
Parco S. Paolo  
80126 Naples, Italy  
Tel: (81) 7679700

## Japan •

John Fluke Mfg. Co., Inc.  
Japan Branch  
Sumitomo Higashi  
Shinbashi Bldg  
1-1-11 Hamamatsucho  
Minato-ku, Tokyo, Japan  
Tel: (03) 434-0181, TLX: 2424331



John Fluke Mfg. Co., Inc. / PO Box C9090 / Everett, WA 98206 / (206) 356 5400

Litho in U.S.A. 1/83

**Kenya** ●  
ADCOM Ltd.  
P.O. Box 30070  
Nairobi, Kenya, East Africa  
Tel: 331955, TLX: 22639

**Korea** ●  
Electro-Science Korea Co.  
C.P.O. Box 8446  
Room 403, Boondo Bldg.  
56-12 Jangchung-IKa  
Jung-ku  
Seoul, Korea  
Tel: 261-7702, TLX: K25381

**Kuwait** ■  
Al-Bahar Int. Group  
P.O. Box 26672 Safat  
Kuwait, Arabian Gulf  
Tel: 4501087, TLX: 44822

**Lebanon and Jordan** ■  
Mabek (Electronic Division)  
P.O. Box 11-3823  
Beirut, Lebanon  
Tel: 812523, TLX: (923) 22889

**Libya** ■  
Fluke (Holland) B.V.  
P.O. Box 5053, 5004 EB Tilburg  
Zevenheuvelenweg 53, 5048 AN Tilburg  
The Netherlands  
Tel: (013) 673973, TLX: 52237

**Malaysia** ●  
Mecomb Malasia SON BHD  
Lot 2, Lorong 13/6A  
Petaling Jaya, Malasia  
Tel: 573455, TLX: MA37605

**Mexico** ●  
Electronica y Tecnologia  
Avanzada S.A. de C.V.  
Pafnucio Padilla 53  
Circuito Comercial Satelite  
Naucalpan Edo. De Mexico  
Tel: 393 0902  
TLX: (383) 017 2697

**Nepal** ●  
Associated Enterprises  
G.P.O. Box 790, Pyaphal Tole  
Kathmandu, Nepal  
Tel: 13868

**Netherlands** ■  
Fluke (Nederland) B.V.  
Gasthuisring 14  
5041 DS Tilburg  
The Netherlands  
  
P.O. Box 115  
5000 AC Tilburg  
The Netherlands  
Tel: (013) 352455, TLX: 52683

**New Zealand** ●  
McLean Information Technology, Ltd.  
P.O. Box 9464, Newmarket  
Auckland 1, New Zealand  
Tel: 501-801, TLX: (791) NZ 215 70  
  
McLean Information Technology, Ltd.  
P.O. Box 496  
Wellington, New Zealand  
Tel: 851-450 or 844-424

**Nigeria** ●  
Mofat Engineering Co., Ltd.  
P.O. Box 6369  
Lagos, Nigeria  
Tel: 960744, TLX: 21353

**Norway** ■  
Morgenstjerne & Co A/S  
Konghellegate 3  
P.O. Box 6688, Rodelokka  
Oslo 5, Norway  
Tel: (2) 356110, TLX: (856) 71719

**Oman** ■  
OHI Communications  
P.O. Box 889  
Muscat  
Sultanate of Oman  
Tel: 702666 or 703862  
TLX: 3168

**Pakistan** ●  
Pak International Operations  
505 Muhammadi House  
I.I. Chundrigar Road  
P.O. Box 5323, Karachi, Pakistan  
Tel: 221127, TLX: (952) 24494

**PDR Yemen** ■  
Fluke (Holland) B.V.  
P.O. Box 5053, 5004 EB Tilburg  
Zevenheuvelenweg 53, 5048 AN Tilburg  
The Netherlands  
Tel: (013) 673973, TLX: 52237

**Peru** ●  
Importaciones Y Representaciones  
Electronicas S.A.  
Avda Franklin D. Roosevelt 105  
Lima 1, Peru  
Tel: 288650, TLX: (394) 25663

**Philippines** ●  
Spark Radio & Electronics Corp.  
1044 Ongpin St., Sta. Cruz  
Manila, Philippines  
Tel: 47-11-94, TLX: 27901  
  
Spark Radio & Electronics Corp  
Greenhills P.O. Box 610  
San Juan, Metro-Manila  
Philippines Zip 3113  
Tel: 77-51-92

**Poland** ■  
Amtest Associates Ltd.  
Clarence House, 31, Clarence St  
Staines, Middlesex TW18 4SY  
United Kingdom  
Tel: (784) 63555, TLX: 928855

**Portugal** ■  
Decada-Equipamentos de  
Electronica, Lda  
Rue Pedro Nunes, 47-C,  
1000 Lisboa, Portugal  
P.O. Box 1128, 1003 Lisboa Codex  
Tel: (19) 574984, TLX: (832) 18469

**Qatar** ■  
Technology Organisation  
P.O. Box 5549, Doha, Qatar  
Tel: 321431, TLX: (957) 4581

**Romania** ■  
Amtest Associates Ltd  
Clarence House, 31, Clarence St  
Staines, Middlesex TW18 4SY  
United Kingdom  
Tel: (784) 63555, TLX: 928855

**Saudi Arabia** ■  
Electronic Equipment Marketing Co.  
P.O. Box 3750  
Riyadh, Saudi Arabia  
Tel: (1) 477-165001  
TLX: (928) 201120

**Singapore** ●  
Rank O'Connor's (PTE) Limited  
98 Pasir Panjang Road  
Singapore 0511  
Republic of Singapore  
Tel: 637944  
TLX: RS21023

**Somalia** ■  
Fluke (Holland) B.V.  
P.O. Box 5053, 5004 EB Tilburg  
Zevenheuvelenweg 53, 5048 AN Tilburg  
The Netherlands  
Tel: (013) 673973, TLX: 52237

**South Africa** ●  
Fluke S.A. (Pty) Ltd  
P.O. Box 39797, Bramley 2018  
Republic of South Africa  
Tel: (011) 786-3170, TLX: 424328

**Spain** ■  
Hispano Electronics S.A.  
Poligono Industrial Urtinsa  
Apartado de Correos 48  
Alcorcon (Madrid), Spain  
Tel: (1) 6194108  
TLX: (831) 22404

**Sri Lanka** ●  
Jay-Es Electronics  
160 Poorvarama Mawatha  
Colombo 5, Sri Lanka  
Tel: 073-2393

**Sweden** ■  
Teleinstrument AB  
P.O. Box 4490  
162 04 Vallingby, Sweden  
Tel: (8) 380370, TLX: (854) 15770

**Switzerland** ■  
Traco Electronic AG  
Jenatschstrasse 1  
8002 Zurich, Switzerland  
Tel: (1) 2010711, TLX: (845) 54318

**Syria** ■  
Mabek (Electronic Division)  
P.O. Box 4238  
Damascus, Syria

**Taiwan** ●  
Schmidt Scientific Far East Ltd  
906, Chia Hsin Bldg.  
96, Chung Shan N. Rd., Sec. 2  
Taipei, Taiwan  
Tel: 5414600, TLX: 111:1

**Thailand** ●  
Measuretronix Ltd  
1899/10 Ramkamhaeng Rd.  
Huamark, Bangkok 24, Thailand  
Tel: 3143369, TLX: 81143

**Tunisia** ■  
Selep S.A.R.L.  
6, Rue de Sparte  
Tunis - 1000 RP, Tunisia  
Tel: (1) 248093, TLX: (934) 13030

**Turkey** ■  
Erkman Elektronik Aletler  
Ticaret Anonim Sirketi  
Necatibey Cad 92/3  
Karakoy, Istanbul, Turkey  
Tel: 441546  
TLX: (821) 23353

**United Arab Emirates** ■  
Al Sanani Trad. Est.  
P.O. Box 7187  
Abu-Dhabi, United Arab Emirates  
Tel: 821370 or 821371  
TLX: 23966

**United Kingdom** ■  
Fluke (Great Britain) Ltd.  
Colonial Way  
Watford, Herts, WD2 4TT  
United Kingdom  
Tel: (0923) 40511, TLX: 934583  
Rapifax (0923) 25067

**Uruguay** ●  
Coasin Uruguaya S.A.  
Casilla de Correos 1400  
Libertad 2529  
Montevideo, Uruguay  
Tel: 78-90-15, TLX: UY6571

**U.S.S.R.** ■  
Amtest Associates Ltd.  
Clarence House, 31, Clarence St  
Staines, Middlesex TW18 4SY  
United Kingdom  
Tel: (784) 63555, TLX: 928855

**Venezuela** ●  
Coasin, C.A.  
Calle 9 Con Calle 4, Edif. Edinurbi  
Apartado De Correos  
NR-70, 136 Los Ruices  
Caracas 1070A, Venezuela  
Tel: 239-0967, TLX: (395) 21027

**Yemen** ■  
Fluke (Holland) B.V.  
P.O. Box 5053, 5004 EB Tilburg  
Zevenheuvelenweg 53, 5048 AN Tilburg  
The Netherlands  
Tel: (013) 673973, TLX: 52237

**Yugoslavia** ■  
Amtest Associates Ltd  
Clarence House, 31, Clarence St  
Staines, Middlesex TW18 4SY  
United Kingdom  
Tel: (784) 63555, TLX: 928855

#### ■ Supplied and Supported by —

Fluke (Holland) B.V.  
P.O. Box 5053, 5004 EB Tilburg  
Zevenheuvelenweg 53, 5048 AN Tilburg  
The Netherlands  
Tel: (013) 673973, TLX: 52237

#### ● Supplied and Supported by —

Fluke International Corporation  
P.O. Box C9090  
Everett, WA 98206 U.S.A.  
Tel: (206) 356-5500  
TLX: 152662 JOHN FLUKE EVT



# U.S. SALES AREAS for all Fluke products

## **AK, Anchorage**

Harry Lang & Associates  
1371 Hillcrest Drive #303  
Anchorage, AK 99503  
(907) 279-5741

## **AL, Huntsville**

John Fluke Mfg. Co., Inc.  
3322 S. Memorial Parkway  
Suite 96  
Huntsville, AL 35801  
(205) 881-6220

## **AZ, Tempe**

John Fluke Mfg. Co., Inc.  
2125 S. 48th Street  
Suite 104  
Tempe, AZ 85282  
(602) 967-8724

## **Tucson**

(602) 790-9881

## **CA, Los Angeles**

John Fluke Mfg. Co., Inc.  
20902 South Bonita St.  
Carson, CA 90746  
(213) 538-3900  
or (714) 761-2449

## **San Diego**

John Fluke Mfg. Co., Inc.  
9601 Aero Drive, Suite 290  
San Diego, CA 92123  
(714) 226-1254

## **Santa Clara**

John Fluke Mfg. Co., Inc.  
2300 Walsh Ave., Bldg. K  
Santa Clara, CA 95051  
(408) 727-0513

## **Tustin**

John Fluke Mfg. Co., Inc.  
15445 Red Hill Ave., Suite F  
Tustin, CA 92680  
(714) 838-8863

## **CO, Denver**

John Fluke Mfg. Co., Inc.  
1980 South Quebec St. #4  
Denver, CO 80231  
(303) 750-1222

## **CT, Hartford**

John Fluke Mfg. Co., Inc.  
Glen Locken East  
41-C New London Turnpike  
Glastonbury, CT 06033  
(203) 659-3541

## **FL, Orlando**

John Fluke Mfg. Co., Inc.  
940 N. Fern Creek Ave.  
Orlando, FL 32803  
(305) 896-4881

## **GA, Atlanta**

John Fluke Mfg. Co., Inc.  
2700 Delk Rd., Suite 250  
Marietta, GA 30067  
(404) 953-4747

## **HI, Honolulu**

EMC Corporation  
2979 Uaiena St.  
Honolulu, HI 96819  
(808) 836-1138

## **IA, Iowa City**

(319) 354-2811

## **IL, Chicago**

John Fluke Mfg. Co., Inc.  
3740 Industrial Ave.  
Rolling Meadows, IL 60008  
(312) 398-0850

## **IN, Indianapolis**

John Fluke Mfg. Co., Inc.  
877 Purdue  
Suite 101  
Indianapolis, IN 46268  
(317) 875-7870

## **KS, Kansas City**

John Fluke Mfg. Co., Inc.  
4550 W. 109th St., Suite 130  
Shawnee Mission, KA 66211  
(913) 381-9800

## **LA, New Orleans**

(504) 455-0814

## **MA, Burlington**

John Fluke Mfg. Co., Inc.  
25 "B" Street  
Burlington MA 01803  
(617) 273-4674

## **MD, Baltimore**

(301) 792-7060

## **Rockville**

John Fluke Mfg. Co., Inc.  
5640 Fishers Lane  
Rockville, MD 20852  
(301) 770-1570

## **MI, Detroit**

John Fluke Mfg. Co., Inc.  
13955 Farmington Rd.  
Livonia, MI 48154  
(313) 522-9140

## **MN, Bloomington**

John Fluke Mfg. Co., Inc.  
1801 E. 79th St., Suite 9  
Bloomington, MN 55420  
(612) 854-5526

## **MO, St. Louis**

John Fluke Mfg. Co., Inc.  
2029 Woodland Parkway  
Suite 105  
St. Louis, MO 63141  
(314) 993-3805

## **NC, Greensboro**

John Fluke Mfg. Co., Inc.  
1310 Beaman Place  
Greensboro, NC 27408  
(919) 273-1918

## **NJ, Paramus**

John Fluke Mfg. Co., Inc.  
P.O. Box 930  
West 75 Century Road  
Paramus, NJ 07652  
(201) 262-9550

## **NM, Albuquerque**

John Fluke Mfg. Co., Inc.  
1108 Alvarado Drive N.E.  
Albuquerque, NM 87110  
(505) 881-3550

## **NY, Rochester**

John Fluke Mfg. Co., Inc.  
4515 Culver Road  
Rochester, NY 14622  
(716) 323-1400

## **OH, Cleveland**

John Fluke Mfg. Co., Inc.  
7830 Freeway Circle  
Middleburg Heights, OH 44130  
(216) 234-4540

## **Columbus**

(614) 889-5715

## **Dayton**

John Fluke Mfg. Co., Inc.  
4756 Fishburg Rd.  
Dayton, OH 45424  
(513) 233-2238

## **OR, Portland**

John Fluke Mfg. Co., Inc.  
18360 S.W. Springfield Lane  
Aloha, OR 97007  
(503) 642-1342

## **PA, Philadelphia**

John Fluke Mfg. Co., Inc.  
1010 West 8th Ave., Suite H  
King of Prussia, PA 19406  
(215) 265-4040

## **Pittsburgh**

(412) 261-5171

## **TX, Austin**

John Fluke Mfg. Co., Inc.  
Creek Gardens, Suite 103  
8705 Shoal Creek Blvd.  
Austin, TX 78758  
(512) 459-3344

## **Dallas**

John Fluke Mfg. Co., Inc.  
14400 Midway Road  
Dallas, TX 75234  
(214) 233-9990

## **Houston**

John Fluke Mfg. Co., Inc.  
4240 Blue Bonnet Dr.  
Stafford, TX 77477  
(713) 491-5995

## **San Antonio**

John Fluke Mfg. Co., Inc.  
10417 Gulfdale  
San Antonio, TX 78216  
(512) 340-2621

## **UT, Salt Lake City**

John Fluke Mfg. Co., Inc.  
5226 So. 300 West, Suite #2  
Salt Lake City, UT 84107  
(801) 268-9331

## **WA, Seattle**

John Fluke Mfg. Co., Inc.  
5020 148th Ave. N.E.  
Suite #110  
Redmond, WA 98052  
(206) 881-6966

## **Service Center Areas**

**CA, Burbank** (213) 849-4641  
**CA, Santa Clara** (408) 727-8121  
**CO, Denver** (303) 750-1228  
**FL, Orlando** (305) 896-2296  
**IL, Chicago** (312) 398-5800  
**MA, Burlington** (617) 273-4678  
**MD, Rockville** (301) 770-1576  
**NJ, Paramus** (201) 262-9550  
**TX, Dallas** (214) 233-9945  
**WA, Everett** (206) 356-5560

### **The following low-cost instruments. . .**

are stocked locally and sold by the authorized Distributors listed on the other side of this sheet, as well as by the sales offices shown.

**Handheld DMM's:** 8020B, 8021B, 8022B, 8024B, 8026B, 8060A, 8062A

**Portable DMM's:** 8000A, 8010A, 8012A, 8030A, 8040A, 8050A

**Digital Counters:** 1900A, 1910A, 1911A, 1912A

**Digital Thermometers:** 2160- and 2170 - Series

All other instruments are sold by the sales offices only.

**For more information on Fluke products or Sales Offices you may dial (800) 426-0361 toll-free in most of U.S.  
From Alaska, Hawaii, or Washington, phone (206) 356-5400. From Canada and other countries phone (206) 356-5500.**



John Fluke Mfg. Co., Inc. P.O. Box C9090, Everett, WA 98206

Fluke (Holland) B.V., P.O. Box 5053, 5004 EB, Tilburg, The Netherlands, Phone (013) 673973

Litho in U.S.A. 8/82









# static awareness



A Message From  
**John Fluke Mfg. Co., Inc.**

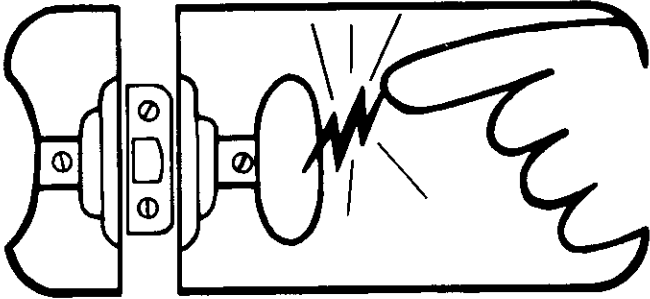

Some semiconductors and custom IC's can be damaged by electrostatic discharge during handling. This notice explains how you can minimize the chances of destroying such devices by:

1. Knowing that there is a problem.
2. Learning the guidelines for handling them.
3. Using the procedures, and packaging and bench techniques that are recommended.

The Static Sensitive (S.S.) devices are identified in the Fluke technical manual parts list with the symbol "⊗".

The following practices should be followed to minimize damage to S.S. devices.

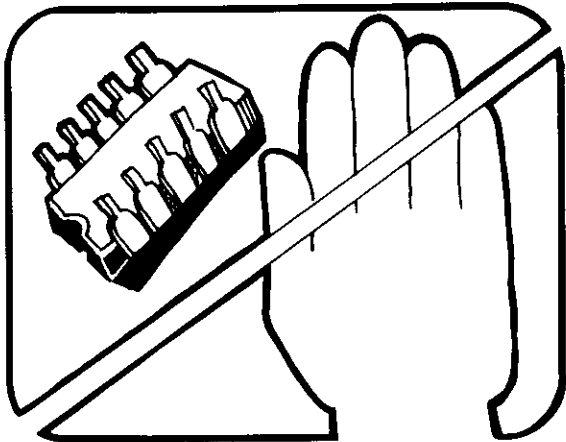

1. MINIMIZE HANDLING

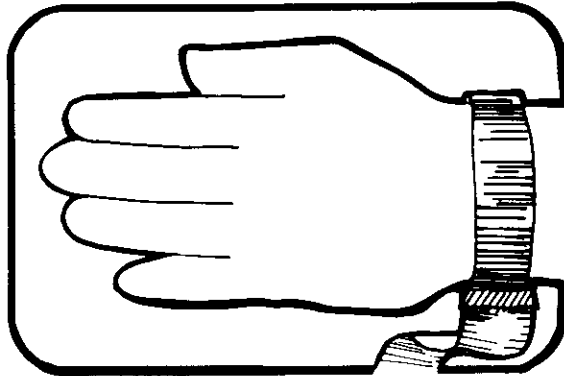

3. DISCHARGE PERSONAL STATIC BEFORE HANDLING DEVICES

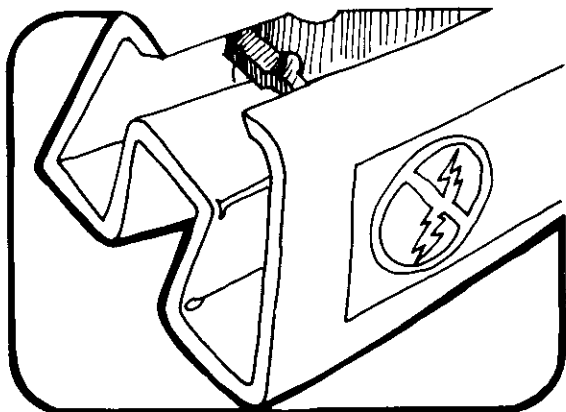

2. KEEP PARTS IN ORIGINAL CONTAINERS UNTIL READY FOR USE.

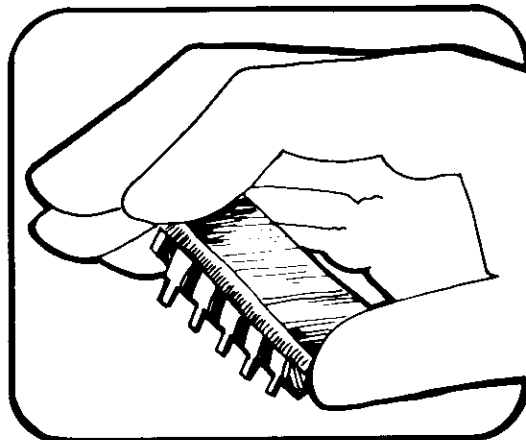

4. HANDLE S.S. DEVICES BY THE BODY

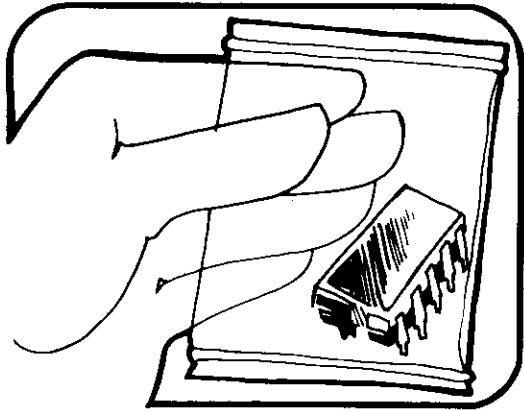

5. USE ANTI-STATIC CONTAINERS FOR HANDLING AND TRANSPORT

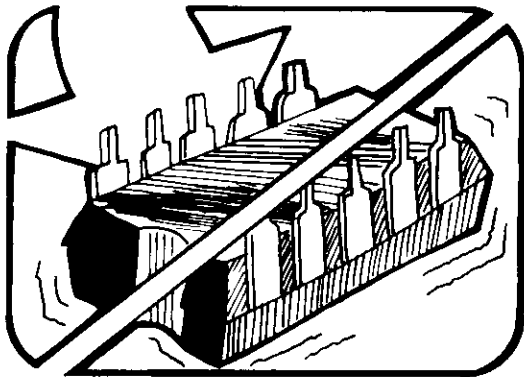

6. DO NOT SLIDE S.S. DEVICES OVER ANY SURFACE

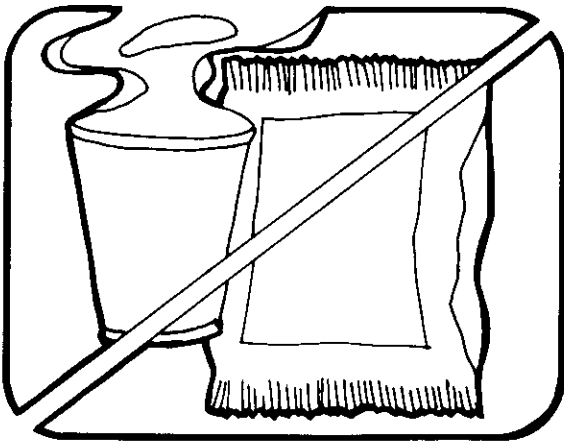

7. AVOID PLASTIC, VINYL AND STYROFOAM® IN WORK AREA

PORTIONS REPRINTED  
WITH PERMISSION FROM TEKTRONIX, INC.  
AND GENERAL DYNAMICS, POMONA DIV.

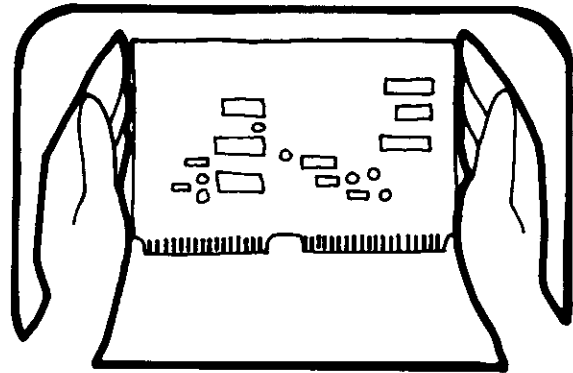

8. WHEN REMOVING PLUG-IN ASSEMBLIES, HANDLE ONLY BY NON-CONDUCTIVE EDGES AND NEVER TOUCH OPEN EDGE CONNECTOR EXCEPT AT STATIC-FREE WORK STATION. PLACING SHORTING STRIPS ON EDGE CONNECTOR USUALLY PROVIDES COMPLETE PROTECTION TO INSTALLED SS DEVICES.

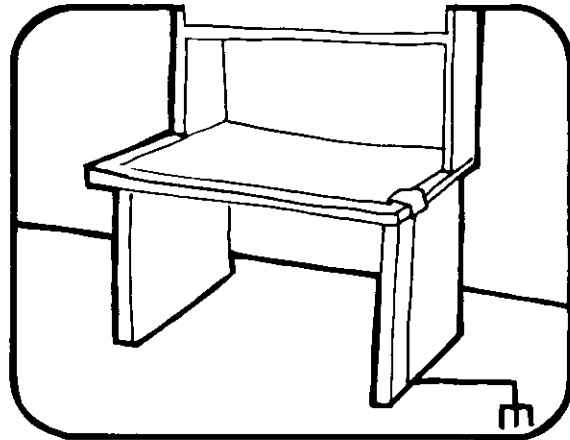

9. HANDLE S.S. DEVICES ONLY AT A STATIC-FREE WORK STATION  
10. ONLY ANTI-STATIC TYPE SOLDER-SUCKERS SHOULD BE USED.  
11. ONLY GROUNDED TIP SOLDERING IRONS SHOULD BE USED.

Anti-static bags, for storing S.S. devices or pcbs with these devices on them, can be ordered from the John Fluke Mfg. Co., Inc.. See section 5 in any Fluke technical manual for ordering instructions. Use the following part numbers when ordering these special bags.

John Fluke Part No.	Description
453522	6" X 8" Bag
453530	8" X 12" Bag
453548	16" X 24" Bag
454025	12" X 15" Bag
Pink Poly Sheet	Wrist Strap
30"x60"x60 Mil	P/N TL6-60
P/N RC-AS-1200	\$7.00
\$20.00	

## Section 3

# Access Procedures

### WARNING

**WHEN THE INSTRUMENT CASE COVER IS REMOVED, HAZARDOUS VOLTAGES MAY BE PRESENT. TO AVOID ELECTRICAL SHOCK, SPECIAL CARE SHOULD BE TAKEN IN THE AREA WHERE LINE POWER ENTERS THE INSTRUMENT.**

### 3-1. INTRODUCTION

3-2. This section of the manual contains two access procedures: the Maintenance and Routine Calibration Access Procedure and the Non-Routine Calibration Access Procedure. When performing either the Line Voltage Selection or Routine Calibration Adjustments procedures, complete the Maintenance and Routine Calibration Access procedure. When performing the Non-Routine Calibration Adjustments procedure, complete the Non-Routine Calibration Access procedure.

### 3-3. MAINTENANCE AND ROUTINE CALIBRATION ACCESS

3-4. Complete the following procedure to gain access to the line voltage selection switches and/or the routine calibration adjustments.

1. Remove the six screws from the top case covers as shown in Figure 3-1.
2. Pull the top case cover off the instrument.
3. The line voltage selection switches cover and all routine calibration adjustments are accessible.
4. Loosen the four screws securing the line voltage selection switch cover and lift the cover straight up, if access to the switches is required.
5. For re-assembly, logically reverse this procedure.

### 3-5. NON-ROUTINE CALIBRATION ACCESS

3-6. Complete the following procedure to gain access to the non-routine calibration adjustments. Use Figure 3-2 for reference:

1. Remove the six screws (A) from the top case cover.
2. Pull the top case cover off the instrument.

3. Remove the four screws (B) from the top and the two screws (C) from the side of the upper guard assembly.
4. Lift the upper guard assembly off the instrument.
5. All non-routine calibration adjustments are now accessible.
6. To reassemble, logically reverse this procedure.

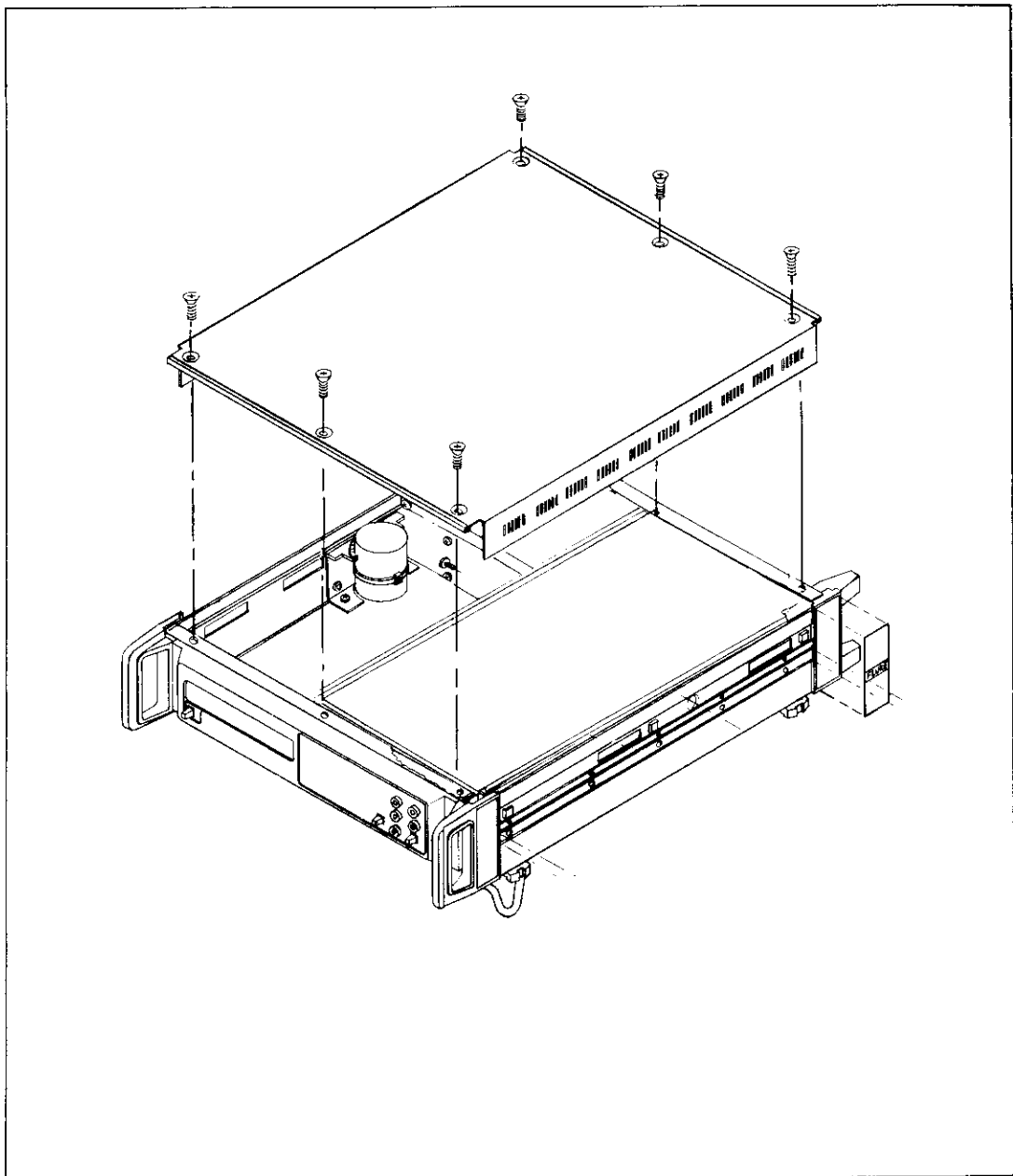

Figure 3-1. Maintenance and Routine Calibration Access

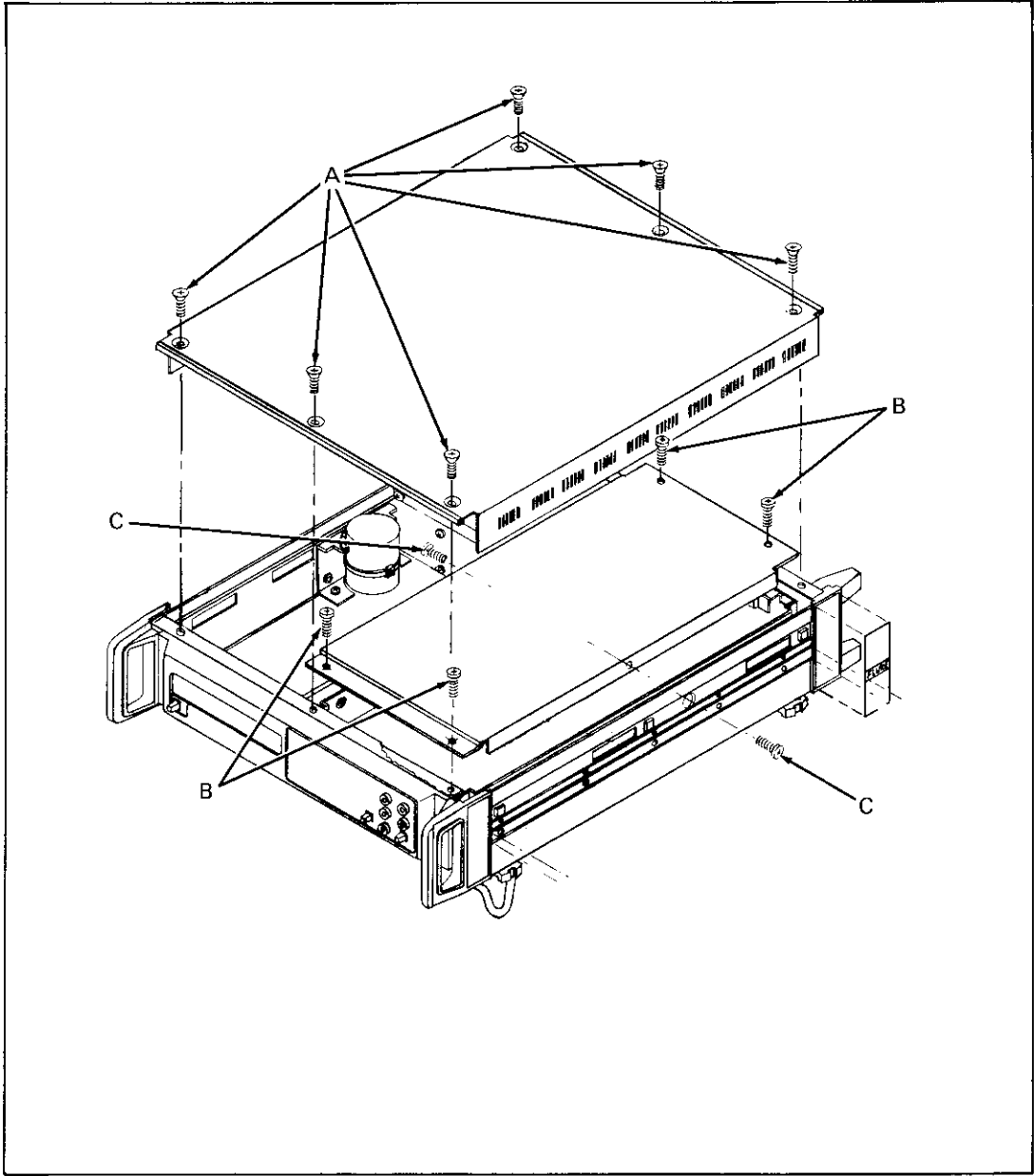

Figure 3-2. Non-Routine Calibration Access



## Section 4

# General Maintenance

### 4-1. INTRODUCTION

4-2. This section of the manual contains the general maintenance procedures. These include cleaning instructions, line voltage selection, and fuse replacement. Do not perform any of these procedures when power is applied to the instrument.

### 4-3. CLEANING INSTRUCTIONS

4-4. Periodically (at least every 90-days) clean the 8520A using the following procedure:

1. Insure power is removed from the 8520A.
2. Remove the top cover and guard, and the bottom cover from the instrument.
3. Clean the interior of the 8520A using low pressure, clean, dry air.
4. Clean the front panel and exterior surfaces with anhydrous ethyl alcohol or a soft cloth, dampened with a mild solution of detergent and water.

### 4-5. LINE VOLTAGE SELECTION

4-6. Input line voltage for the 8520A may be switch selected from one of four voltages (100, 120, 220, 240)  $\pm 10\%$  at frequencies of 50, 60, or 400  $\pm 5\%$  Hertz. Two slide switches are used to select the desired line voltage. The switches are mounted on the power supply transformer located in the left rear of the instrument compartment. Figure 4-1 shows the switches set for the four possible input line voltages. Set the switches using the dot and slot as pictured. When the line voltage settings are changed insure the correct fuse is installed for the setting selected.

### 4-7. FUSE REPLACEMENT

4-8. Check to insure that the proper fuse is installed for the input line voltage selected. Select the applicable fuse from those listed below:

For 100 or 120V AC, use MDL  $\frac{1}{2}$

For 220 or 240V AC, use MDL  $\frac{1}{4}$

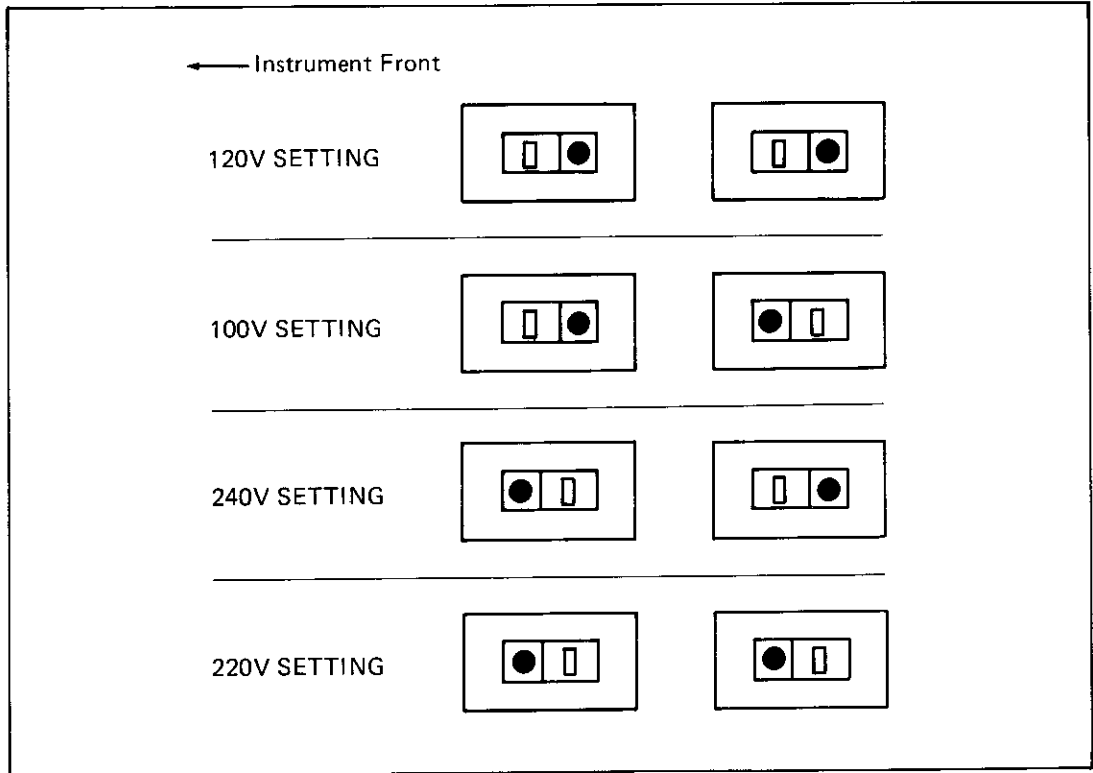

Figure 4-1. Line Voltage Selection Switches



## Section 5

# Performance Test

### 5-1. INTRODUCTION

5-2. The following paragraphs contain a performance verification test which compares the instrument's performance to the specifications given in Section 1 of this manual. The test is recommended as an acceptance test when the unit is first received, and later as a calibration procedure to verify instrument accuracy at the scheduled calibration periods, either the normal 90 days or the alternates, 24 hours or 1 year. It is also useful as an aid in troubleshooting.

5-3. Test equipment required for the performance test is listed earlier in Table 1-1. If the recommended equipment is not available, comparable instruments with equivalent specifications may be substituted. To ensure optimum results, the test must be performed at an ambient temperature of 22 to 24 degrees Celsius, with a relative humidity of less than 70%. Also, the instrument should be allowed to warm-up for at least 1 hour before starting the performance test.

5-4. If the instrument does not meet the performance test, troubleshooting, repair, and/or calibration adjustment is indicated. Procedures for calibration adjustment are given later in this manual. Troubleshooting procedures are given in the Service Manual.

### 5-5. EQUIPMENT PREPARATION

5-6. Perform the following procedure prior to beginning the performance test:

1. Verify the instrument is set for the applicable line voltage using the procedure previously given.
2. Install any guard or outer covers not in place.
3. Connect the instrument to the input line power.
4. Depress the POWER switch to apply line voltage to the instrument.
5. Select Front Panel inputs and NORMAL guard.
6. Allow the instrument to operate for at least 2 hours before beginning the test.

### 5-7. ZERO VERIFICATION

5-8. Use the following procedure to verify proper meter zeroing:

1. Select the DC Voltage Function and the 100 mV range. The 2 reading per second rate and 500 msec filter are selected automatically with the function.

2. Short the 8520A input terminals.
3. Perform steps 1 through 6 of Table 5-1.
4. Remove the short from the 8520A input terminals.

Table 5-1. Zero Verification

STEP	FUNCTION	RANGE	READING RATE	INPUT	DISPLAY READING
1	V DC	100 mV	2/sec	Short	.000 mV $\pm 6 \mu\text{V}$ (6 digits)
2	V DC	100 mV	10/sec	Short	.000 mV $\pm 6 \mu\text{V}$ (6 digits)
3	V DC	1V	2/sec	Short	.00000V $\pm 20 \mu\text{V}$ (2 digits)
4	V DC	10V	2/sec	Short	.0000V $\pm 100 \mu\text{V}$ (1 digit)
5	V DC	100V	2/sec	Short	.000V $\pm 2 \text{ mV}$ (2 digits)
6	V DC	1000V	2/sec	Short	.00V $\pm 10 \text{ mV}$ (1 digit)

## 5-9. DC VOLTS VERIFICATION

5-10. Use the following procedure to verify proper operation of the V DC measurement function:

1. Connect the equipment as shown in Figure 5-1.
2. Set the DC Voltage Calibrator controls for a 10V output and set the Ratio Standard to .0100000.
3. Select the DC volts function and the 100 mV range. The 2 readings per second rate and 500 msec filter are selected automatically with the function.
4. Select Operate on the DC Voltage Calibrator.
5. Perform step 1 through 10 of Table 5-2, changing the ratio standard and 8520A range settings as required. Record the displayed reading in step 10 of the table.
6. Select a Ratio Standard setting of .088888 and a DC Voltage Standard output (approximately 100 volts) that obtains the recorded display obtained in step 5 above, i.e., step 10 of Table 5-2.
7. Perform step 11 of Table 5-2, setting the Ratio Standard and 8520A range as required.
8. Disconnect the Ratio Standard from the equipment and connect the DC Voltage Standard directly to the 8520A input terminals, output HI to input HI and LO to LO.
9. Perform the steps in Table 5-3, changing the DC Voltage Standard output and 8520A range settings as required.
10. Disconnect the DC Voltage Standard from the 8520A.



5. Connect the AC Calibrator/ Power Amplifier combination output to the 8520A input terminals.
6. Perform steps 16 through 19 of Table 5-5, setting the AC Calibrator output, and 8520A range as required.
7. Disconnect all test equipment from the 8520A.
8. This completes the performance test of the 8520A.

Table 5-5. AC Voltage Verification

STEP	AC CALIBRATOR OUTPUT		8520A RANGE	DISPLAY READING BETWEEN:
	VOLTAGE	FREQUENCY		
1	1.100000V	40.00 Hz	1V	1.09830 – 1.10170 (170 digits)
2	1.000000V	20.00 kHz	1V	0.99840 – 1.00160 (160 digits)
3	1.000000V	100.00 kHz	1V	0.98400 – 1.01600 (1600 digits)
4	1.000000V	300.00 kHz	1V	0.96400 – 1.03600 (3600 digits)
5	1.000000V	1.000 MHz	1V	0.87000 – 1.1300 (13,000 digits)
6	2.00000 mV	20.000 kHz	1V	.00140 – .00260 (60 digits)
7	10.00000V	1.0000 kHz	10V	9.9852 – 10.0148 (148 digits)
8	10.00000V	20.000 kHz	10V	9.9852 – 10.0148 (148 digits)
9	10.00000V	100.00 kHz	10V	9.8520 – 10.1480 (1480 digits)
10	10.00000V	300.00 kHz	10V	9.6640 – 10.3360 (3360 digits)
11	10.00000V	1.0000 MHz	10V	8.8000 – 11.2000 (12000 digits)
12	100.0000V	1.0000 kHz	100V	99.861 – 100.139 (139 digits)
13	100.0000V	20.000 kHz	100V	99.861 – 100.139 (139 digits)
14	100.0000V	100.00 kHz	100V	98.610 – 101.390 (1390 digits)
15	50.0000V	200.00 kHz	100V	48.020 – 51.980 (1980 digits)
16	600.0000V	1.0000 kHz	1000V	599.10 – 600.90 (90 digits)
17	600.0000V	20.000 kHz	1000V	599.10 – 600.90 (90 digits)
18	600.0000V	30.000 kHz	1000V	590.93 – 609.07 (907 digits)
19	100.0000V	100.00 kHz	1000V	95.93 – 104.07 (407 digits)

## 5-11. RESISTANCE VERIFICATION

5-12. Use the following procedure to verify proper operation of the resistance measurements functions:

1. Select the  $\Omega$  4-wire function and 10 $\Omega$  range. Select one reading per second, which automatically selects the 1000 msec filter.
2. Short the V/ $\Omega$  INPUT HI and LO leads, the  $\Omega$  SOURCE HI and LO leads and then connect the shorted leads with a jumper.
3. The 8520A display reads .0000  $\pm$ 0.7 m $\Omega$  (7 digits).
4. Select the 2 readings per second rate, which automatically selects the 500 msec filter.
5. Perform steps 1 through 7 of Table 5-4, applying the Standard Resistance, and selecting the listed 8520A range.
6. Compute the value of the 10 M $\Omega$  standard resistor in nano-siemens by dividing 1 by the corrected standard value, i.e., take the reciprocal of the corrected standard value. The result should be approximately 100 nS.
7. Perform step 8 of Table 5-4.
8. Disconnect the Standard Resistor from the 8520A.

Table 5-4. Resistance Verification

STEP	NOMINAL STANDARD RESISTOR VALUE	8520A RANGE	CORRECTED STANDARD VALUE READING $\pm$ TOLERANCE
1	10 $\Omega$	10 ohm	10 $\Omega$ $\pm$ 1.5 m $\Omega$ (15 digits)
2	100 $\Omega$	100 ohm	100 $\Omega$ $\pm$ 9 m $\Omega$ (9 digits)
3	1000 $\Omega$	1000 ohm	1000 $\Omega$ $\pm$ 90 m $\Omega$ (9 digits)
4	10 k $\Omega$	10 kohm	10 k $\Omega$ $\pm$ .9 $\Omega$ (9 digits)
5	100 k $\Omega$	100 kohm	100 k $\Omega$ $\pm$ 11 $\Omega$ (11 digits)
6	1 M $\Omega$	1 Mohm	1 M $\Omega$ $\pm$ 180 $\Omega$ (18 digits)
7	10 M $\Omega$	10 Mohm	10 M $\Omega$ $\pm$ 5 k $\Omega$ (5 digits)
8	10 M $\Omega$	100 nS	100nS $\pm$ .10nS (10 digits)

## 5-13. AC VOLTAGE VERIFICATION

5-14. Use the following procedure to verify proper operation of the V AC function:

1. Select the AC Volts function and the 1 volt range. The 2 readings per second rate and 500 msec filter are selected automatically with the function.
2. Connect the AC Calibrator output to the 8520A input terminals.
3. Perform step 1 through 15 of Table 5-5, setting the AC Calibrator output, and 8520A range as required.
4. Disconnect the AC Calibrator from the 8520A.

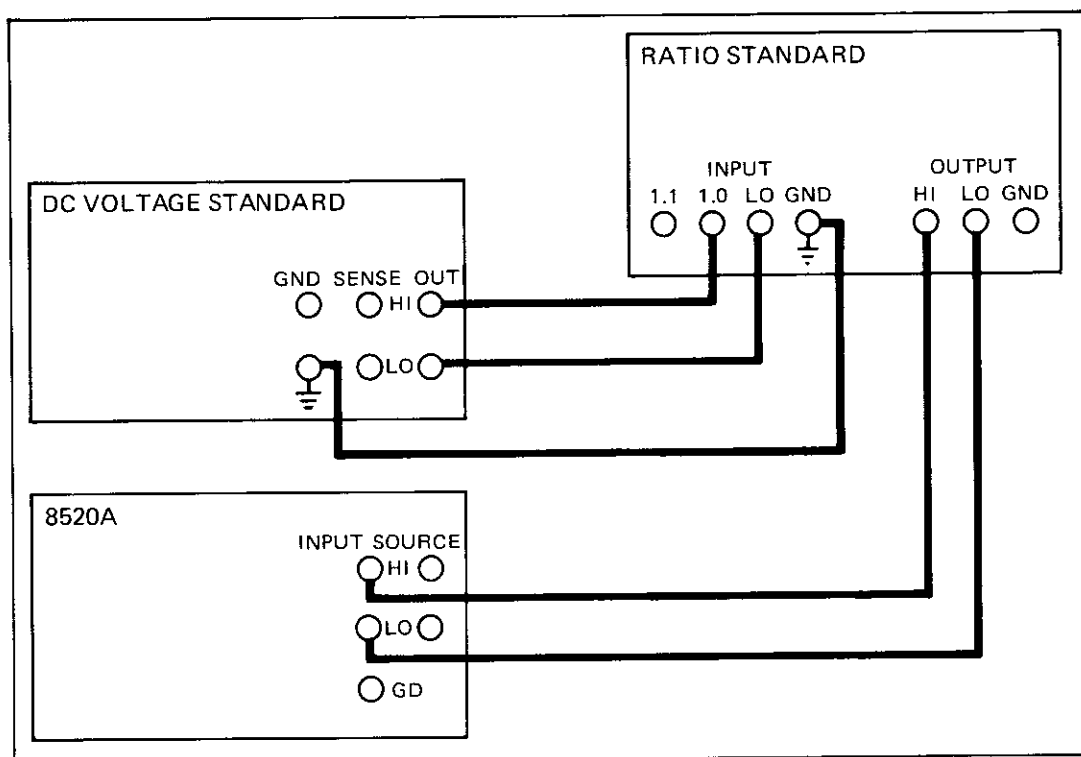

Figure 5-1. DC Voltage Verification

Table 5-2. Low DC Volts Verification

STEP	RANGE	RATIO STANDARD	INPUT	DISPLAY READING
1	100 mV	.0100000	100 mV	100 mV $\pm$ 12 $\mu$ V (12 digits)
2	1V	.0111110	.11111V	.11111V $\pm$ 30 $\mu$ V (3 digits)
3	1V	.0222220	.22222V	.22222V $\pm$ 30 $\mu$ V (3 digits)
4	1V	.0444440	.44444V	.44444V $\pm$ 50 $\mu$ V (5 digits)
5	1V	.0888880	.88888V	.88888V $\pm$ 70 $\mu$ V (7 digits)
6	1V	.1111110	1.1111V	1.1111V $\pm$ 90 $\mu$ V (9 digits)
7	10V	.111110	1.1111V	1.1111V $\pm$ .2mV (2 digits)
8	10V	.222220	2.2222V	2.2222V $\pm$ .2 mV (2 digits)
9	10V	.444440	4.4444V	4.4444V $\pm$ .3 mV (3 digits)
10	10V	.888880	8.8888V	8.8888V $\pm$ .5 mV (5 digits)
11	10V	.111111	11.111V	11.111V $\pm$ .7 mV (7 digits)

Table 5-3. High DC Volts Verification

STEP	DC VOLTAGE STANDARD OUTPUT	8520A RANGE	DISPLAY READING
1	11.111V	100V	11.111V $\pm$ 3 mV (3 digits)
2	22.222V	100V	22.222V $\pm$ 4 mV (4 digits)
3	44.444V	100V	44.444V $\pm$ 5 mV (5 digits)
4	88.888V	100V	88.888V $\pm$ 8 mV (8 digits)
5	111.111V	100V	111.111V $\pm$ 10 mV (10 digits)
6	111.11V	1000V	111.11V $\pm$ 20 mV (2 digits)
7	222.22V	1000V	222.22V $\pm$ 20 mV (2 digits)
8	444.44V	1000V	444.44V $\pm$ 40 mV (4 digits)
9	888.88V	1000V	888.88V $\pm$ 70 mV (7 digits)
10	1000.00V	1000V	1000.00V $\pm$ 80 mV (8 digits)

## **Section 6**

# **Calibration Adjustments**

### **6-1. ROUTINE CALIBRATION ADJUSTMENTS**

#### **6-2. Introduction**

6-3. The calibration adjustment procedures given in the following paragraphs should be performed after repair of the 8520A and/or when the unit fails the performance-test requirements. If the unit will not respond to, or meet the limits of the adjustment procedures, troubleshooting and repair is indicated. Equipment required for the calibration adjustments is listed earlier in Table 1-1.

6-4. All calibration adjustments are accessible when the top cover is removed from the 8520A. The locations of the assemblies, test points, and adjustments that must be accessed to complete the routine calibration adjustment procedures are placarded on the instrument guard cover.

6-5. To ensure optimum results, the calibration adjustments must be performed at an ambient temperature of 22 to 24 degrees Celsius, with a relative humidity of less than 85%. Also the unit should be allowed to warm-up for at least 1 hour before starting the adjustments procedures.

6-6. Instrument accuracies during the first 24 hours after calibration and for one year after calibration are given in the instrument specification. If accuracies within either of these levels are desired the calibration interval can be adjusted accordingly.

6-7. The 8520A contains three calibration procedures (+5V Power Supplies, Ref Amp, and Auto Zero) that are performed at the factory and do not require further adjustment unless components are replaced within the circuit. These adjustments and the special handling required, are detailed at the end of the calibration procedure in a paragraph titled "Non-Routine Calibration Adjustments".

#### **6-8. Calibration (Cal) Digit**

6-9. When selected, the Cal digit appears at the left position of the alphanumeric display to add an additional digit of resolution. This moves the displayed data one position to the right, truncating the right character. The Cal digit is used in the calibration of the dc volt and ohms features. It is switch selectable with an internal push-push switch and is accessible only with the top cover removed.

6-10. Designated S1 on the Digital PCB, the switch causes the Cal digit feature to change states, enabling it if it had been disabled, or disabling it if it had been enabled. The Cal digit feature is automatically disabled if power is removed or a RESET occurs.

Depression of the switch is required to re-enable the feature. The Cal digit feature cannot be selected in remote operation.

### **6-11. Routine Calibration Preparation**

6-12. Prepare the 8520A for routine calibration using the following procedure:

1. Perform the Routine Calibration Access procedure given in Section 3.

*NOTE*

*Do not remove the inner guard cover for a routine calibration.*

2. Apply power to the 8520A and allow the instrument to warm-up for 1 hour before beginning the adjustment procedure.

*NOTE*

*The ambient temperature during the warm-up period and the subsequent calibration should be between 22° C and 24° C with the relative humidity less than 70%.*

### **6-13. Reference Supply**

6-14. Use the following procedure to perform calibration adjustments on the Reference Supply:

1. Connect the test DMM to TP504 (HI) and TP501 (LO).
2. Depress the RESET keyswitch twice, holding it depressed the second time, short the instrument input terminals. Maintain this condition until the adjustment procedure is complete.
3. Adjust R503 POS REF for a test DMM reading of +6.5000V dc.
4. Connect the test DMM to TP501 (HI) and TP503 (LO).
5. Adjust R504 NEG REF for a test DMM reading of +6.5000V dc.
6. Release the RESET keyswitch and remove the test DMM from the instrument.

### **6-15. A/D Converter**

6-16. Use the following procedure to complete the A/D Converter calibration adjustments:

1. Select the dc volts function, the 10V range, the 2 reading/sec rate, the 1000 msec filter, and the Cal digit feature, in that sequence.
2. Short the instrument input terminals.
3. Adjust R513 for an instrument display of .0000 0  $\pm$ 2 Cal digits.



4. Connect the equipment as shown in Figure 6-1, i.e., with the DC Calibrator output connected to the Ratio Standard input LO, and the DC Calibrator output LO to the Ratio Standard 1.0 input.
5. Set the Ratio Standard to .8100000.
6. Select a +10.00000V DC Calibrator output.
7. Adjust R522 for an instrument display of  $-8.1000\ 0 \pm 2$  Cal digits.
8. Set the DC Calibrator to STANDBY then reverse the output leads at the DC Calibrator. Return the DC Calibrator to OPERATE to obtain an instrument input of  $+8.1000\ 0V$  dc.
9. Adjust R504 for an instrument display of  $+8.1000\ 0 \pm 2$  Cal digits.
10. Perform steps 6 through 9 until both readings are within the stated tolerance without adjustment.
11. Perform the checks and adjustments in Table 6-1.

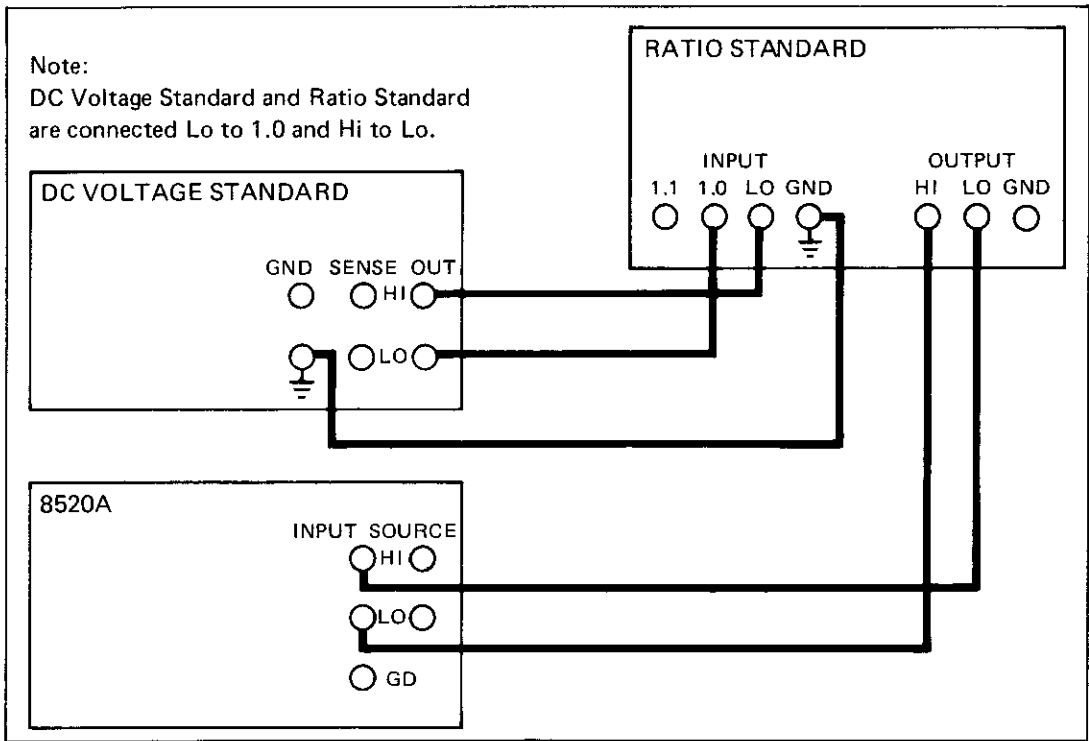

Figure 6-1. A/D Converter Calibration

Table 6-1. A/D Converter Calibration

	VOLTAGE CALIBRATOR SETTING	RATIO STD. SETTING	8520A INPUT	ADJUSTMENT	DISPLAY $\pm$ CAL DIGITS
1	+10V	.4100000	4.1V	R521	4.1000 0 $\pm 2$
2	+10V	.2100000	2.1V	R520	2.1000 0 $\pm 2$
3	+10V	.1100000	1.1V	R519	1.1000 0 $\pm 2$
4	+10V	.0600000	0.6V	R518	.6000 0 $\pm 2$
5	+10V	.0300000	0.3V	R527	.3000 0 $\pm 2$

12. Select a ratio standard setting of 0.0800000 and a DC Voltage Calibrator output of 100V dc.
13. Adjust the DC Voltage Calibrator for an 8520A display of  $8.0000\ 0 \pm 2$  Cal digits.
14. Verify the display readings in Table 6-2. These are no adjustments for these readings.
15. Set the DC Calibrator to STANDBY then reverse the DC Calibrator output leads. Return the DC Calibrator to OPERATE to obtain a negative input to the 8520A.
16. Repeat the steps in Table 6-2 and verify that the readings are as shown, but of a negative polarity.
17. Depress the CAL switch to disable to the CAL Digit feature.
18. Disconnect the test equipment from the instrument.

Table 6-2. A/D Converter Tests

STEP	RATIO STANDARD SETTING	8520A INPUT	DISPLAY $\pm$ CAL DIGITS
1	.0100000	1.0V	1.0000 0 $\pm 2$
2	.0200000	2.0V	2.0000 0 $\pm 2$
3	.0300000	3.0V	3.0000 0 $\pm 4$
4	.0400000	4.0V	4.0000 0 $\pm 2$
5	.0500000	5.0V	5.0000 0 $\pm 4$
6	.0600000	6.0V	6.0000 0 $\pm 6$
7	.0700000	7.0V	7.0000 0 $\pm 6$
8	.0800000	8.0V	8.0000 0 $\pm 2$
9	.0900000	9.0V	9.0000 0 $\pm 8$
10	.1000000	10.0V	10.0000 0 $\pm 10$
11	.1100000	11.0V	11.0000 0 $\pm 12$
12	.1200000	12.0V	12.0000 0 $\pm 15$
13	.1300000	13.0V	13.0000 0 $\pm 15$
14	.1400000	14.0V	14.0000 0 $\pm 15$
15	.1500000	15.0V	15.0000 0 $\pm 15$
16	.1600000	16.0V	16.0000 0 $\pm 15$

### 6-17. DC Buffer

- 6-18. Use the following procedure to complete the DC Buffer calibration adjustments:
  1. Short the 8520A input terminals.
  2. Select the volts dc function and the 100 mV range.
  3. Select the 2 readings per second rate, which automatically selects the 500 msec filter.
  4. Adjust C231 for a reading of  $.000\ \text{mV} \pm 1\ \mu\text{V}$ .

5. Select the 10 readings per second rate, which automatically selects the 100 msec filter.
6. Adjust C225 for equal alternations between the plus and minus signs.
7. Repeat steps 3 through 6 until both readings are within the stated tolerance without adjustment.
8. Remove the short on the input terminals and replace it with the 1 M $\Omega$ /1  $\mu$ F parallel load.
9. Select the 2 readings per second rate then verify that the instrument displays .000 mV  $\pm$ 50  $\mu$ V.
10. Remove the load from the input terminals.
11. Connect the 8520A to the DC Calibrator and Ratio Standard as shown in Figure 5-1 for a positive input to the 8520A.
12. Select a DC Voltage Calibrator output of 10V and set the Ratio Standard to .0190000.
13. Adjust R253 for an 8520A display reading of 190.000 mV  $\pm$ 2 digits.
14. Select the 1 volts range and the Cal digit feature on the 8520A.
15. Set the Ratio Standard to .190000.
16. Adjust R251 for an 8520A display reading of 1.90000 0  $\pm$ 6 Cal digits.
17. Set the DC Calibrator to STANDBY and remove the ratio standard from the circuit, connecting the DC Calibrator directly to the 8520A for a positive input, i.e., HI to HI and LO to LO.
18. Select the 100 volts range on the 8520A.
19. Select a DC Voltage Calibrator output of 120.000V dc.
20. Adjust R109 for an 8520A display reading of 120.000 0  $\pm$ 6 Cal digits.
21. Disconnect the DC Calibrator from the 8520A.

## 6-19. Ohms Converter

6-20. Complete the Ohms Converter calibration adjustments by performing, in sequence, each step in Table 6-3. Manually select the range indicated and short the input in step 1 at the far end of the input leads. When the adjustments are complete depress the CAL digit switch to disable the CAL digit feature.

Table 6-3. Ohms Converter Calibration

STEP	FUNCTION	RANGE IN OHMS	READING RATE	FILTER	STANDARD RESISTOR INPUT	ADJUSTMENT	DISPLAY ± CAL DIGIT
1	Ω4 WIRE	10	2/sec	500msec	Short	R325	.0000 0 ±20
2	Ω4 WIRE	10k	2/sec	500msec	10k	R311	10.0000 0 ±15
3	Ω4 WIRE	1000	2/sec	500msec	1k	R314	1.00000 0 ±15
4	Ω4 WIRE	100	2/sec	500msec	100	R317	100.000 0 ±15
5	Ω2 WIRE	100k	2/sec	Fast	100k	R315	100.000 0 ±20
6	Ω2 WIRE	1M	1/sec	Slow	1M	R319	1.00000 0 ±20

## 6-21. AC Converter

6-22. Use the following procedure to complete the AC Converter calibration procedures:

1. Select the AC plus DC function and the 1 volt range. The 2 readings per second rate and 500 msec filter are selected automatically with the function.
2. Short the 8520A input terminals.
3. Connect a test DMM set for the 100 mV dc range to J418 (HI) and TP402 (LO).

### NOTE

*TP402 is not placarded on the guard cover, however, it is accessible through the J418 or R440 slots.*

4. Adjust R408 for a test DMM reading of 0.000 mV ±15 μV (15 digits). Record the reading.
5. Remove the short from the input terminals and the test DMM from the circuit.

### NOTE

*J418 is a removable jumper. Exercise caution removing the DMM probe from the jumper.*

6. Connect a DC Voltage Standard to the 8520A input terminals for a negative input. The 8520A remains in the AC plus DC function and 1 volt range previously selected.
7. Perform steps 1 and 2 of Table 6-4. Repeat until both steps are within the stated tolerance without further adjustment.
8. Perform step 3 and 4 of Table 6-4. Repeat step 1 through 4 of the table until all are within the listed tolerance without further adjustment.
9. Select the AC voltage function and the 1 volt range. The 2 readings per second rate and 500 msec filter are selected automatically with the function.
10. Repeat steps 1 through 5 of the procedure, adjusting R408 for the reading recorded in step 4.
11. Connect an AC Voltage Calibrator output to the 8520A input terminals.
12. Perform steps 1 through 8 of Table 6-5.
13. Remove the test equipment from the instruments.
14. The calibration procedure is complete.

Table 6-4. AC Converter AC + DC Calibration

STEP	INPUT	ADJUSTMENT	READING
1	-.0040000	R463	-.00400V $\pm 50 \mu\text{V}$ (5 digits)
2	+.0040000	R445	+.00400V $\pm 50 \mu\text{V}$ (5 digits)
3	-1.000000	-	Record Reading
4	+1.000000	R440	Recorded Reading $\pm 200 \mu\text{V}$ (20 digits)

Table 6-5. AC Converter AC Calibration

STEP	RANGE	INPUT	ADJUSTMENT	DISPLAY
1	1V	1.6V ac @ 200 Hz	R481	1.60000V $\pm 80 \mu\text{V}$ (8 digits)
2	10V	11V ac @ 200 Hz	R422	11.0000V $\pm 600 \mu\text{V}$ (6 digits)
3	100V	100V ac @ 200 Hz	R433	100.000V $\pm 6 \text{ mV}$ (6 digits)
4	1000V	600V ac @ 200 Hz	R438	600.00V $\pm 60 \text{ mV}$ (6 digits)
5	1000V	600V ac @ 20 kHz	C403	600.00V $\pm 150 \text{ mV}$ (15 digits)
6	1V	1.6V ac @ 20 kHz	C408	1.60000V $\pm 120 \mu\text{V}$ (12 digits)
7	10V	11V ac @ 20 kHz	R425	11.0000V $\pm 1.2 \text{ mV}$ (12 digits)
8	100V	110V ac @ 20 kHz	R426	110.000V $\pm 12 \text{ mV}$ (12 digits)

## 6-23. NON-ROUTINE CALIBRATION ADJUSTMENTS

### 6-24. Introduction

6-25. The Calibration adjustments listed in the following sub-paragraphs are non-recurring in nature and should be performed only when a component has been changed in the applicable circuit. The others may be verified, if desired, at that time.

### 6-26. Preparing for Non-Routine Calibration

6-27. Allow a 2 hour warm-up period before beginning any of the procedures, then complete the Non-Routine Calibration Access procedure in Section 3 and perform the adjustments. When the procedure is complete replace the inner guard cover and allow the operating temperature to stabilize with an additional 30 minute warm-up period before doing a Performance Test or Routine Calibration Adjustment.

### 6-28. Power Supply

6-29. Use the following procedure to complete the Power Supply calibration adjustments:

1. Connect the test DMM set for approximately 5V dc to TP201 (HI) and TP202 (LO) on the digital assembly.
2. Adjust R204 for a reading between +4.9 and +5.2V dc.
3. Transfer the test DMM leads to TP701 (HI) and TP702 (LO) on the Analog Assembly.
4. Adjust R710 for a reading between +4.9 and +5.2V dc.
5. Remove the test equipment from the instruments.

### 6-30. Auto Zero

6-31. Use the following procedure to complete the Auto Zero Calibration Adjustments:

1. Short the instrument input terminals.
2. Select volts dc, 100 mV range, and the 2 reading/sec rate (which automatically selects the 500 msec filter).
3. Connect an oscilloscope between TP206 and TP207 (ground).
4. Adjust R236 for an oscilloscope display with the squarewave amplitude less than 10 mV peak-to-peak as shown in Figure 6-2. (Suggested initial oscilloscope settings are 20 ms/cm and 100 mV/div, then adjust for at least two repetitions of the waveform).

*NOTE*

*The 10 mV waveform measurement is made on the body of the squarewave; ignore the spikes.*

5. Remove test equipment from the instrument.

### 6-32. Reference Amplifier

6-33. Some units have a small PCB assembly installed in the A/D Converter section in place of U501. Two different configurations of the assembly are used, one parallel and the other perpendicular to the Analog Assembly; however, both are electrically identical. When the Ref Amp assembly is installed use the following procedure to re-adjust the circuit if any component in it is changed. If either U2, R15, or R16 fail, they must be replaced as a matched set.

1. Connect a test DMM to the cathode CR1 (HI) on the Ref Amp Assembly and TP501 (LO) on the A/D Converter section of the Analog Assembly.

*NOTE*

*The point monitored is the electrical junction of R1, R2, R3, R15, and the cathode of CR1.*

2. Adjust R3 on the Ref Amp Assembly for a DMM reading of 11V dc  $\pm$  20 mV dc.
3. Remove the test equipment from the instrument.

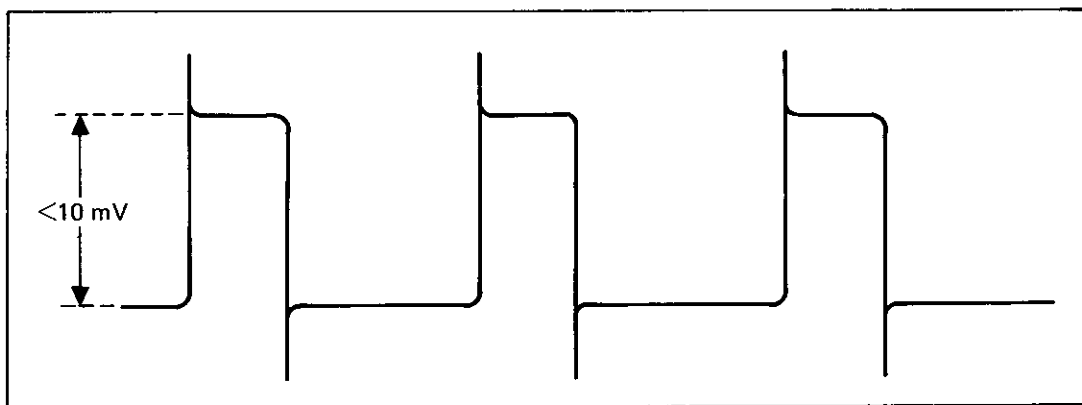

Figure 6-2. Auto Zero Calibration Waveform